



FEATURES

- 14-bit resolution
- 3MHz minimum sampling rate
- Ideal for both frequency and time-domain applications
- Excellent peak harmonics, -83dB
- Excellent signal-to-noise ratio, 79dB
- No missing codes over full HI-REL temperature range
- ±5V supplies, 1.7 Watts
- Small, 24-pin ceramic DDIP or SMT
- Low cost

PRODUCT OVERVIEW

The low-cost ADS-943 is a 14-bit, 3MHz sampling A/D converter optimized to meet the demanding dynamic-range and sampling-rate requirements of contemporary digital telecommunications applications. The ADS-943's outstanding dynamic performance is evidenced by a peak harmonic specification of -83dB and a signal-to-noise ratio (SNR) of 79dB. Additionally, the ADS-943 easily achieves the 2.2MHz minimum sampling rate required by digital receivers in certain ADSL, HDSL and ATM applications. The ADS-943 also addresses size and power constraints normally associated with these types of applications. This device requires just ±5V supplies, dissipates 1.7 Watts, and is packaged in a very small 24-pin DDIP.

Although optimized for frequency-domain applications, the ADS-943's DNL and noise specifications are also outstanding, thereby making it an equally impressive device for time-domain applications (graphic and medical imaging, process control, etc.). In fact, the ADS-943 guarantees no missing codes to the 14-bit level over the full HI-REL operating temperature range.

The functionally complete ADS-943 contains a fast-settling sample-hold amplifier, a subranging (two-pass) A/D converter, an internal reference, timing/control logic, and error-correction circuitry.

Digital input and output levels are TTL. The unit is edge-triggered, requiring only the rising edge of a start convert pulse to initiate a conversion. The device is offered with a bipolar input range of ±2V. Models are available in commercial (0 to +70°C), industrial (-40 to +100°C), or HI-REL (-55 to +125°C) operating temperature ranges. A proprietary, auto-calibrating, error-correcting circuit allows the device to achieve specified performance over the full HI-REL temperature range.

INPUT/OUTPUT CONNECTIONS			
PIN	FUNCTION	PIN	FUNCTION
1	BIT1 (MSB)	24	ANALOG GROUND
2	BIT 2	23	OFFSET ADJUST
3	BIT 3	22	+5V ANALOG SUPPLY
4	BIT 4	21	ANALOG INPUT
5	BIT 5	20	-5V SUPPLY
6	BIT 6	19	ANALOG GROUND
7	BIT 7	18	START CONVERT
8	BIT 8	17	EOC
9	BIT 9	16	BIT 14 (LSB)
10	BIT 10	15	BIT 13
11	BIT 11	14	DIGITAL GROUND
12	BIT 12	13	+5V DIGITAL SUPPLY

BLOCK DIAGRAM

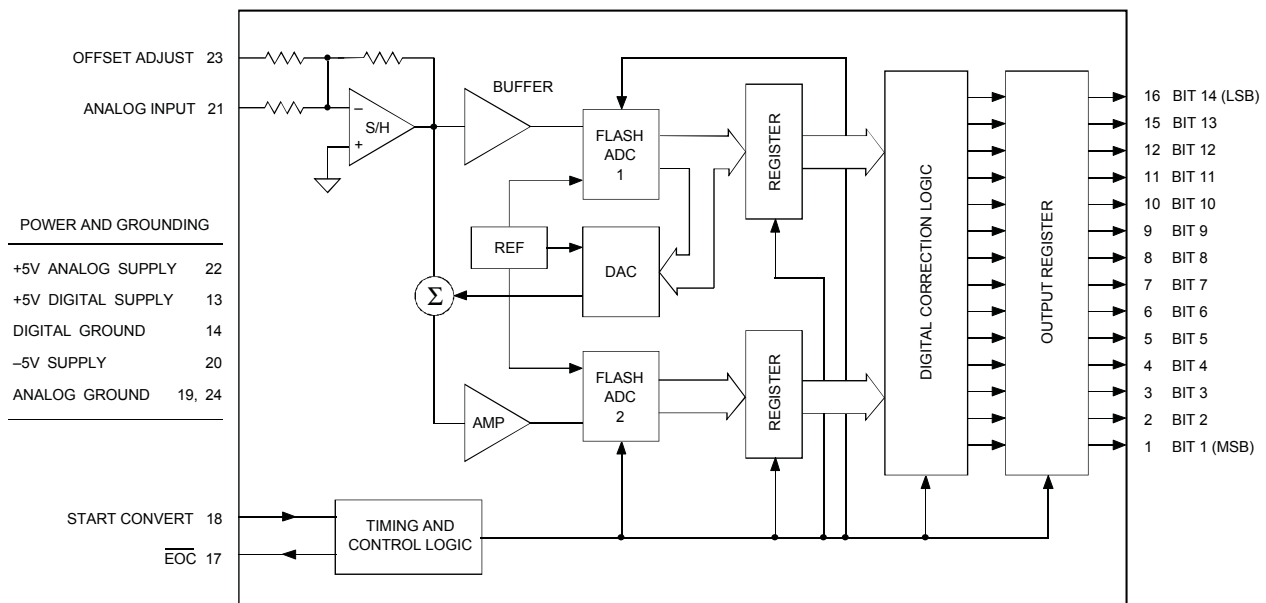

Figure 1. ADS-943 Functional Block Diagram

ABSOLUTE MAXIMUM RATINGS		
PARAMETERS	LIMITS	UNITS
+12V/+15V Supply (Pin 22)	0 to +6	Volts
-12V/-15V Supply (Pin 24)	0 to -6	Volts
+5V Supply (Pin 13)	0 to +6	Volts
Digital Input (Pin 16)	-0.3 to +V _{DD} +0.3	Volts
Analog Input (Pin 20)	±5	Volts
Lead Temperature (10 seconds)	+300	°C

PHYSICAL/ENVIRONMENTAL				
PARAMETERS	MIN.	TYP.	MAX.	UNITS
Operating Temp. Range, Case				
ADS-943MC, GC, MC-C, GC-C	0	—	+70	°C
ADS-943ME, GE, ME-C, GE-C	-40	—	+100	°C
ADS-943MM, GM, MM-C, GM-C	-55	—	+125	°C
ADS-943MM-QL, 883, MM-QL-C, 883-C	-55	—	+125	°C
Thermal Impedance				
θ _{jc}	—	6	—	°C/Watt
θ _{ca}	—	24	—	°C/Watt
Storage Temperature Range				
	-65	—	+150	°C
Package Type				
	24-pin, metal-sealed, ceramic DDIP or SMT			
Weight				
	0.42 ounces (12 grams)			

FUNCTIONAL SPECIFICATIONS

(T_A = +25°C, +V_{DD} = +5V, 3MHz sampling rate, and a minimum 3 minute warmup ① unless otherwise specified.)

ANALOG INPUT	+25°C			0 TO +70°C			-55 TO +125°C			UNITS
	MIN.	TYP.	MAX.	MIN.	TYP.	MAX.	MIN.	TYP.	MAX.	
Input Voltage Range ②	—	±2	—	—	±2	—	—	±2	—	Volts
Input Resistance	—	280	—	—	280	—	—	280	—	Ω
Input Capacitance	—	6	15	—	6	15	—	6	15	pF
DIGITAL INPUT										
Logic Levels										
Logic "1"	+2.0	—	—	+2.0	—	—	+2.0	—	—	Volts
Logic "0"	—	—	+0.8	—	—	+0.8	—	—	+0.8	Volts
Logic Loading "1"	—	—	+20	—	—	+20	—	—	+20	μA
Logic Loading "0"	—	—	-20	—	—	-20	—	—	-20	μA
Start Convert Positive Pulse Width ③	10	20	—	10	20	—	10	20	—	
STATIC PERFORMANCE										
Resolution	—	14	—	—	14	—	—	14	—	Bits
Integral Nonlinearity (fin = 10kHz)	—	±0.75	—	—	±0.75	—	—	±1	—	LSB
Differential Nonlinearity (fin = 10kHz)	-0.95	±0.5	+1.25	-0.95	±0.5	+1.25	-0.95	±0.75	+1.5	LSB
Full Scale Absolute Accuracy	—	±0.15	±0.4	—	±0.15	±0.4	—	±0.4	±0.6	%FSR
Bipolar Zero Error (Tech Note 2)	—	±0.1	±0.3	—	±0.1	±0.3	—	±0.3	±0.6	%FSR
Gain Error (Tech Note 2)	—	±0.2	±0.5	—	±0.2	±0.5	—	±0.4	±1.25	%
No Missing Codes (fin = 10kHz)	14	—	—	14	—	—	14	—	—	Bits
No Missing Codes (fin = 10kHz)	14	—	—	14	—	—	14	—	—	Bits
DYNAMIC PERFORMANCE										
Peak Harmonics (-0.5dB)										
dc to 500kHz	—	-83	-77	—	-83	-77	—	-81	-75	dB
500kHz to 1MHz	—	-83	-77	—	-83	-77	—	-81	-75	dB
1MHz to 1.5MHz	—	-83	-77	—	-83	-77	—	-81	-75	dB
Total Harmonic Distortion (-0.5dB)										
dc to 500kHz	—	-80	-76	—	-80	-76	—	-78	-74	dB
500kHz to 1MHz	—	-80	-76	—	-80	-76	—	-77	-73	dB
1MHz to 1.5MHz	—	-80	-76	—	-80	-76	—	-77	-73	dB
Signal-to-Noise Ratio (w/o distortion, -0.5dB)										
dc to 500kHz	76	79	—	76	79	—	75	78	—	dB
500kHz to 1MHz	76	79	—	76	79	—	74	77	—	dB
1MHz to 1.5MHz	75	78	—	75	78	—	74	77	—	dB
Signal-to-Noise Ratio ④ (& distortion, -0.5dB)										
dc to 500kHz	73	77	—	73	77	—	71	75	—	dB
500kHz to 1MHz	73	77	—	73	77	—	71	75	—	dB
1MHz to 1.5MHz	73	77	—	73	77	—	71	74	—	dB
Noise	—	125	—	—	125	—	—	125	—	μVrms
Two-Tone Intermodulation Distortion (fin = 975kHz, 1.2MHz, fs = 3MHz, -0.5dB)										
Input Bandwidth (-3dB)	—	-82	—	—	-82	—	—	-82	—	dB
Small Signal (-20dB input)										
Large Signal (-0dB input)	—	30	—	—	30	—	—	30	—	MHz
Feedthrough Rejection (fin = 1.5MHz)	—	85	—	—	85	—	—	85	—	dB
Slew Rate	—	±400	—	—	±400	—	—	±400	—	V/μs
Aperture Delay Time	—	+5	—	—	+5	—	—	+5	—	ns
Aperture Uncertainty	—	2	—	—	2	—	—	2	—	ps rms
S/H Acquisition Time (to ±0.003%FSR, 4V step)	—	208	215	—	208	215	—	208	215	ns
Overvoltage Recovery Time ⑤	—	100	333	—	100	333	—	100	333	ns
A/D Conversion Rate	3	—	—	3	—	—	3	—	—	MHz

DIGITAL OUTPUTS	+25°C			0 TO +70°C			-55 TO +125°C			UNITS
	MIN.	TYP.	MAX.	MIN.	TYP.	MAX.	MIN.	TYP.	MAX.	
Logic Levels										
Logic "1"	+2.4	—	—	+2.4	—	—	+2.4	—	—	Volts
Logic "0"	—	—	+0.4	—	—	+0.4	—	—	+0.4	Volts
Logic Loading "1"	—	—	-4	—	—	-4	—	—	-4	mA
Logic Loading "0"	—	—	+4	—	—	+4	—	—	+4	mA
Output Coding	Offset Binary									
POWER REQUIREMENTS										
Power Supply Ranges [Ⓞ]										
+5V Supply	+4.75	+5.0	+5.25	+4.75	+5.0	+5.25	+4.9	+5.0	+5.25	Volts
-5V Supply	-4.75	-5.0	-5.25	-4.75	-5.0	-5.25	-4.9	-5.0	-5.25	Volts
Power Supply Currents										
+5V Supply	—	+210	+230	—	+210	+230	—	+210	+230	mA
-5V Supply	—	-180	-195	—	-180	-195	—	-180	-195	mA
Power Dissipation	—	1.7	2.0	—	1.7	2.0	—	1.7	2.0	Watts
Power Supply Rejection	—	—	±0.05	—	—	±0.05	—	—	±0.05	%FSR/%V

Footnotes:

- ① All power supplies must be on before applying a start convert pulse. All supplies and the clock (START CONVERT) must be present during warmup periods. The device must be continuously converting during this time.
- ② Contact DATEL for availability of other input voltage ranges.
- ③ A 3MHz clock with a 20nsec positive pulse width is used for all production testing. When sampling at 3MHz, the start convert pulse must be between 10 and 110nsec wide or between 160 and 300nsec wide. The falling edge must not occur between 110 and 160nsec. For lower sampling rates, wider start pulses may be used.

④ Effective bits is equal to:

$$(SNR + Distortion) - 1.76 + \frac{\left[20 \log \frac{\text{Full Scale Amplitude}}{\text{Actual Input Amplitude}} \right]}{6.02}$$

- ⑤ This is the time required before the A/D output data is valid after the analog input is back within the specified range. This time is only guaranteed if the input does not exceed ±2.2V (S/H Saturation Voltage).
- ⑥ The minimum supply voltages of +4.9V and -4.9V for ±VDD are required for -55°C operation only. The minimum limits are +4.75V and -4.75V when operating at +125°C.

TECHNICAL NOTES

1. Obtaining fully specified performance from the ADS-943 requires careful attention to pc-card layout and power supply decoupling. The device's analog and digital ground systems are connected to each other internally. For optimal performance, tie all ground pins (14, 19 and 24) directly to a large **analog** ground plane beneath the package.

Bypass all power supplies to ground with 4.7µF tantalum capacitors in parallel with 0.1µF ceramic capacitors. Locate the bypass capacitors as close to the unit as possible.
2. The ADS-943 achieves its specified accuracies without the need for external calibration. If required, the device's small initial offset and gain errors

can be reduced to zero using the adjustment circuitry shown in Figures 2 and 3. When using this circuitry, or any similar offset and gain-calibration hardware, make adjustments following warmup. To avoid interaction, always adjust offset before gain.

3. Applying a start convert pulse while a conversion is in progress (EOC = logic "1") will initiate a new and inaccurate conversion cycle. Data for the interrupted and subsequent conversions will be invalid.
4. A passive bandpass filter is used at the input of the A/D for all production testing.

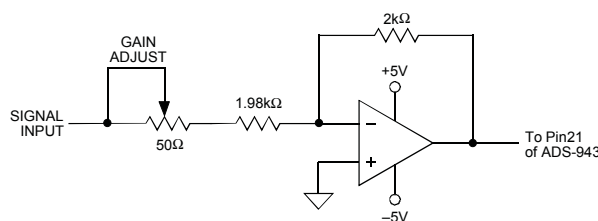

Figure 2. Optional ADS-943 Gain Adjust Calibration Circuit

CALIBRATION PROCEDURE

Any offset and/or gain calibration procedures should not be implemented until devices are fully warmed up. To avoid interaction, offset must be adjusted before gain. The ranges of adjustment for the circuits in Figures 2 and 3 are guaranteed to compensate for the ADS-943's initial accuracy errors and may not be able to compensate for additional system errors.

A/D converters are calibrated by positioning their digital outputs exactly on the transition point between two adjacent digital output codes. This can be accomplished by connecting LED's to the digital outputs and adjusting until certain LED's "flicker" equally between on and off. Other approaches employ digital comparators or microcontrollers to detect when the outputs change from one code to the next.

Offset adjusting for the ADS-943 is normally accomplished at the point where the MSB is a 1 and all other output bits are 0's and the LSB just changes from a 0 to a 1. This digital output transition ideally occurs when the applied analog input is $+\frac{1}{2}$ LSB (+122 μ V).

Gain adjusting is accomplished when all bits are 1's and the LSB just changes from a 1 to a 0. This transition ideally occurs when the analog input is at +full scale minus $\frac{1}{2}$ LSB's (+1.99963V).

Zero/Offset Adjust Procedure

1. Apply a train of pulses to the START CONVERT input (pin 18) so the converter is continuously converting.
2. Apply +122 μ V to the ANALOG INPUT (pin 21).
3. Adjust the offset potentiometer until the output bits are 10 0000 0000 0000 and the LSB flickers between 0 and 1.

Gain Adjust Procedure

1. Apply +1.99963V to the ANALOG INPUT (pin 21).
2. Adjust the gain potentiometer until all output bits are 1's and the LSB flickers between 1 and 0.
3. To confirm proper operation of the device, vary the input signal to obtain the output coding listed in Table 2.

Table 1. Gain and Zero Adjust

INPUT VOLTAGE RANGE	ZERO ADJUST $+\frac{1}{2}$ LSB	GAIN ADJUST $+FS - \frac{1}{2}$ LSB
$\pm 2V$	+122 μ V	+1.99963V

Table 2. Output Coding for Bipolar Operation

BIPOLAR SCALE	INPUT VOLTAGE ($\pm 2V$ RANGE)	OFFSET BINARY	
		MSB	LSB
+FS - 1 LSB	+1.99976	11 1111 1111 1111	
+3/4FS	+1.50000	11 1000 0000 0000	
+1/2FS	+1.00000	11 0000 0000 0000	
0	0.00000	10 0000 0000 0000	
-1/2 FS	-1.00000	01 0000 0000 0000	
-3/4 FS	-1.50000	00 1000 0000 0000	
-FS +1 LSB	1.99976	00 0000 0000 0001	
-FS	-2.00000	00 0000 0000 0000	

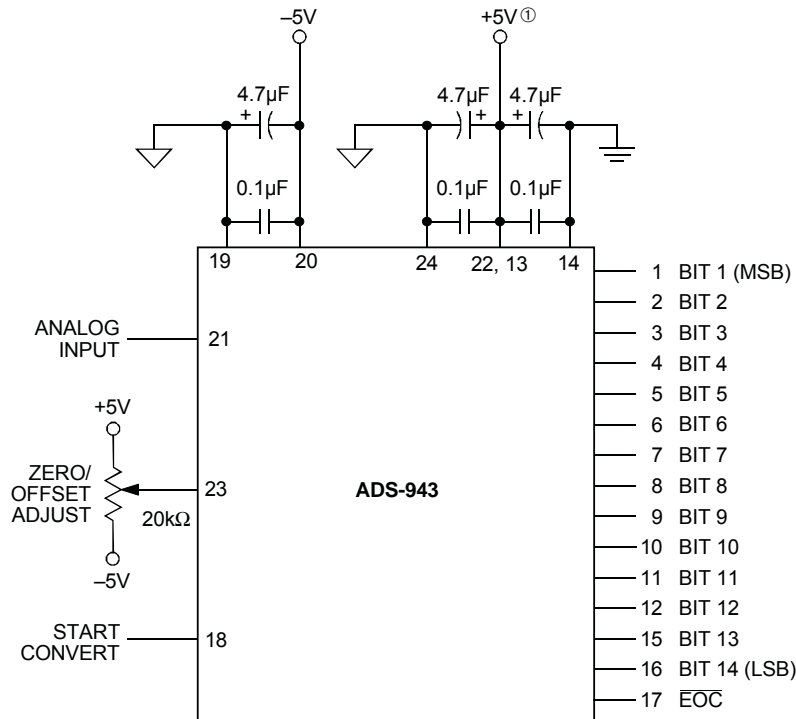

① A single +5V supply should be used for both the +5V analog and +5V digital. If separate supplies are used, the difference between the two cannot exceed 100mV.

Figure 3. Connection Diagram

THERMAL REQUIREMENTS

All DATEL sampling A/D converters are fully characterized and specified over operating temperature (case) ranges of 0 to +70°C and -55 to +125°C. All room-temperature ($T_A = +25^\circ\text{C}$) production testing is performed without the use of heat sinks or forced-air cooling. Thermal impedance figures for each device are listed in their respective specification tables.

These devices do not normally require heat sinks; however, standard precautionary design and layout procedures should be used to ensure

devices do not overheat. The ground and power planes beneath the package, as well as all pcb signal runs to and from the device, should be as heavy as possible to help conduct heat away from the package.

Electrically-insulating, thermally-conductive "pads" may be installed underneath the package. Devices should be soldered to boards rather than "socketed," and of course, minimal air flow over the surface can greatly help reduce the package temperature.

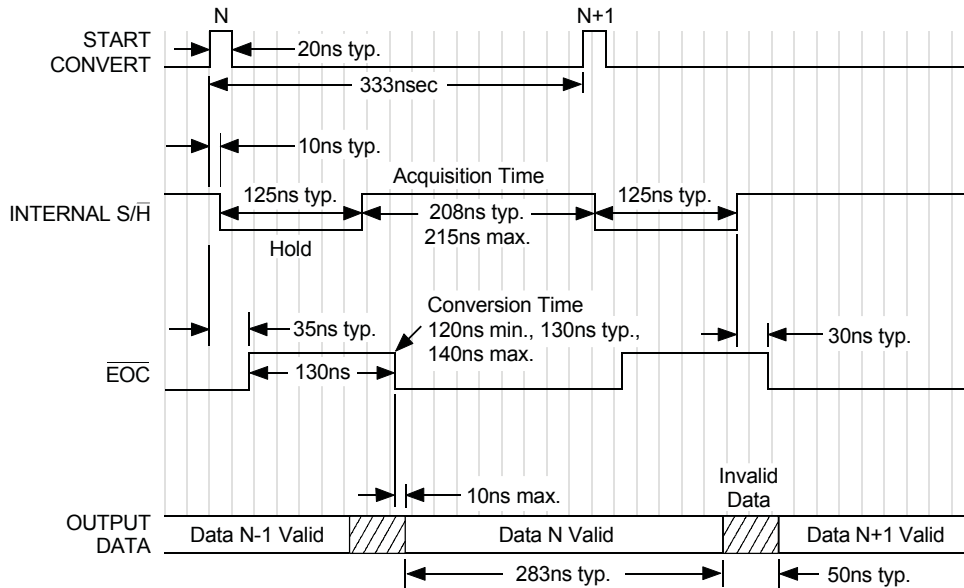

- Note: 1. Scale is approximately 20ns per division. Sampling rate = 3MHz.
 2. The start convert positive pulse width must be between either 10 and 110nsec or 160 and 300nsec (when sampling at 3MHz) to ensure proper operation. For sampling rates lower than 3MHz, the start pulse can be wider than 300nsec, however a minimum pulse width low of 30nsec should be maintained. A 3MHz clock with a 20nsec positive pulse width is used for all production testing.

Figure 4. ADS-943 Timing Diagram

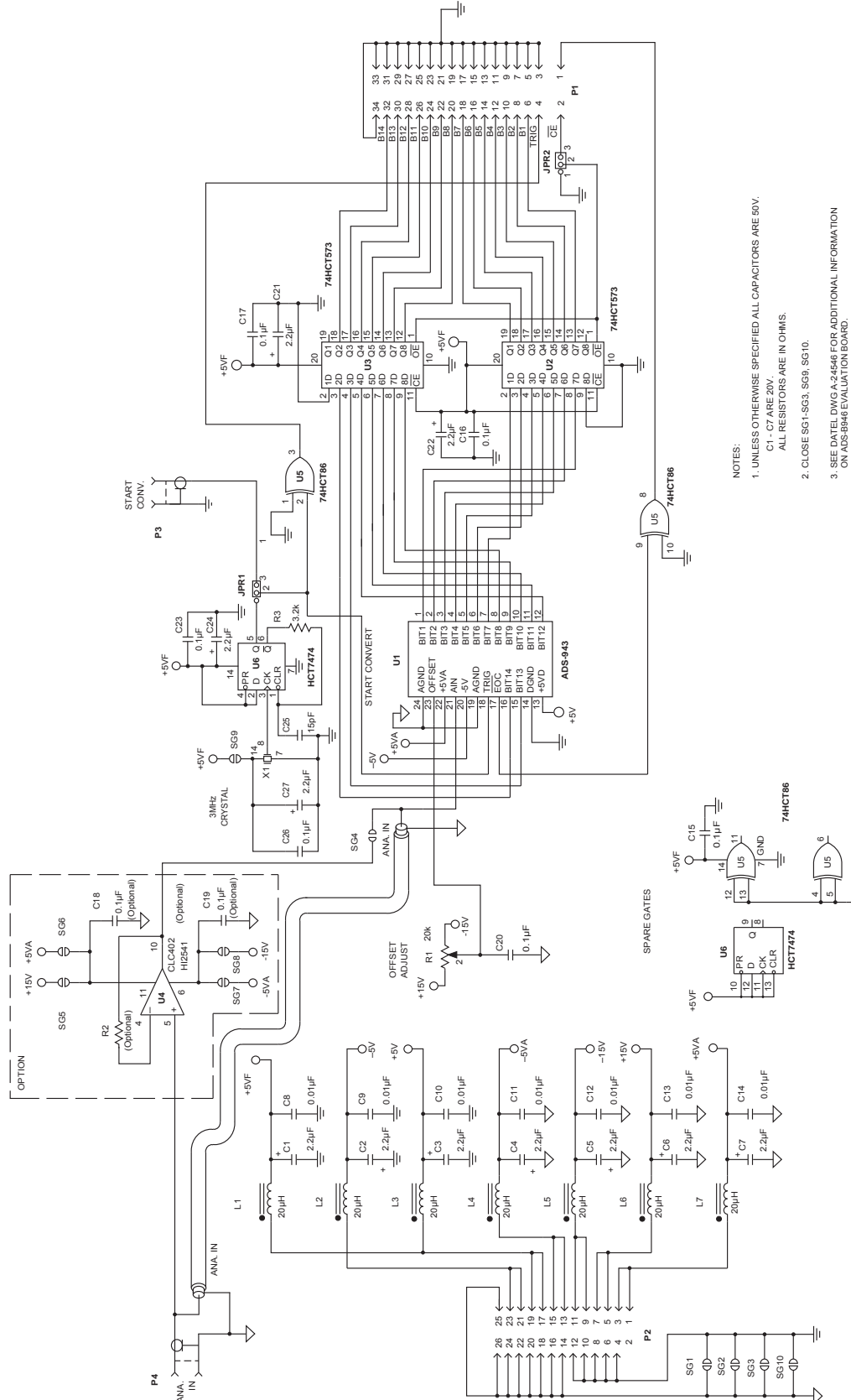

NOTES:
1. UNLESS OTHERWISE SPECIFIED ALL CAPACITORS ARE 50V.
C1 - C7 ARE 20V.
ALL RESISTORS ARE IN OHMS.
2. CLOSE SG1-SG3, SG8, SG9, SG10.
3. SEE DATEL DWG A-24546 FOR ADDITIONAL INFORMATION
ON ADS-8946 EVALUATION BOARD.

Figure 5. ADS-943 Evaluation Board Schematic

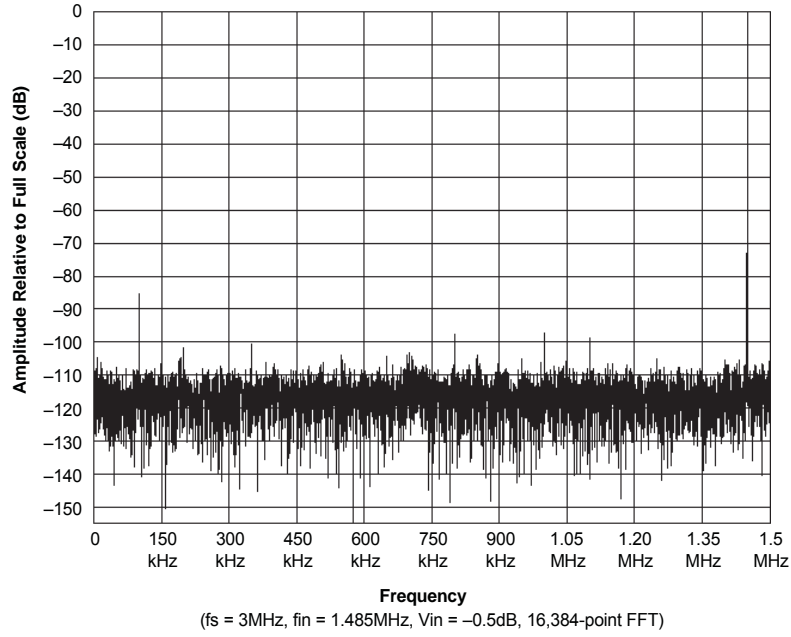

Figure 6. ADS-943 FFT Analysis

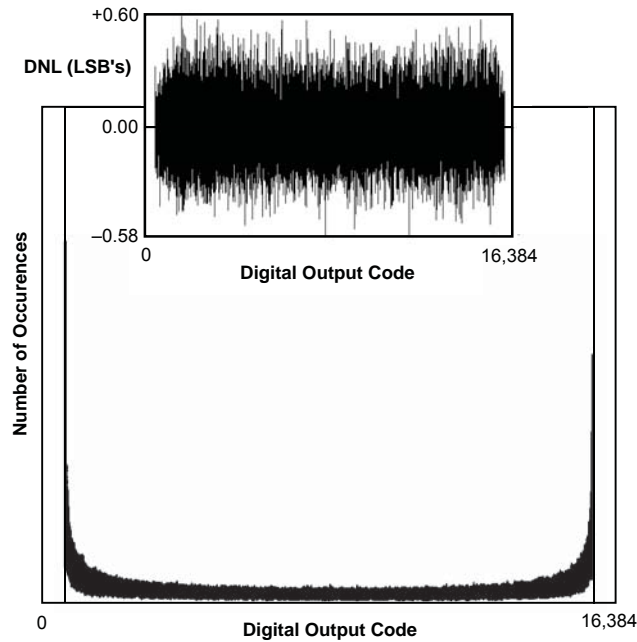
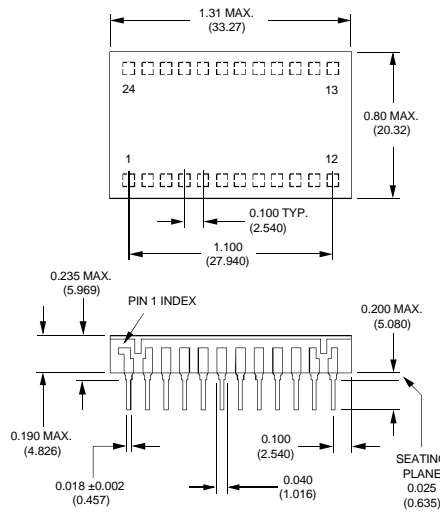

Figure 7. ADS-943 Histogram and Differential Nonlinearity

MECHANICAL DIMENSIONS - INCHES (mm)

24-Pin DDIP Versions

- ADS-943MC
- ADS-943ME
- ADS-943MM
- ADS-943/883
- ADS-943MC-C
- ADS-943ME-C
- ADS-943MM-C
- ADS-943-C/883



Dimension Tolerances (unless otherwise indicated):
 2 place decimal (.XX) ±0.010 (±0.254)
 3 place decimal (.XXX) ±0.005 (±0.127)

Lead Material: Kovar alloy
Lead Finish: 50 microinches (minimum) gold plating over 100 microinches (nominal) nickel plating

24-Pin Surface Mount Versions

- ADS-943GC
- ADS-943GE
- ADS-943GM
- ADS-943G/883
- ADS-943GC-C
- ADS-943GE-C
- ADS-943GM-C
- ADS-943G-C/883

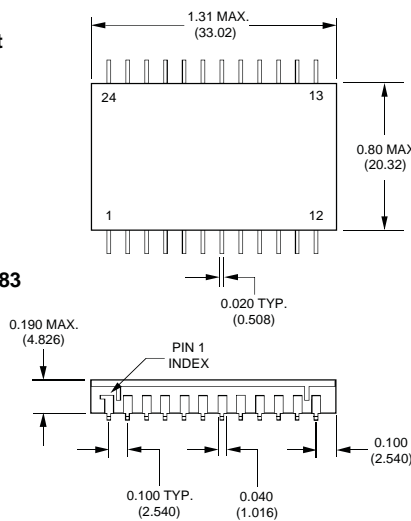

Dimension Tolerances (unless otherwise indicated):
 2 place decimal (.XX) ±0.010 (±0.254)
 3 place decimal (.XXX) ±0.005 (±0.127)

Lead Material: Kovar alloy
Lead Finish: 50 microinches (minimum) gold plating over 100 microinches (nominal) nickel plating

ORDERING INFORMATION					
MODEL NUMBER	OPERATING TEMP. RANGE	PACKAGE	ROHS	ACCESSORIES	
ADS-943MC	0 to +70°C	DDIP	No	ADS-B943	Evaluation Board (without ADS-943)
ADS-943MC-C	0 to +70°C	DDIP	Yes	HS-24	Heat Sinks for all ADS-943 DDIP models.
ADS-943ME	-40 to +100°C	DDIP	No	Receptacles for PC board mounting can be ordered through AMP Inc. Part #3-331272-8 (Component Lead Socket), 24 required. For MIL-STD-883 product specifications, contact DATEL.	
ADS-943ME-C	-40 to +100°C	DDIP	Yes		
ADS-943MM	-55 to +125°C	DDIP	No		
ADS-943MM-C	-55 to +125°C	DDIP	Yes		
ADS-943MM-QL	-55 to +125°C	DDIP	No		
ADS-943MM-QL-C	-55 to +125°C	DDIP	Yes		
ADS-943/883	-55 to +125°C	DDIP	No		
ADS-943-C/883	-55 to +125°C	DDIP	Yes		
ADS-943GC	0 to +70°C	SMT	No		
ADS-943GC-C	0 to +70°C	SMT	Yes		
ADS-943GE	-40 to +100°C	SMT	No		
ADS-943GE-C	-40 to +100°C	SMT	Yes		
ADS-943GM	-55 to +125°C	SMT	No		
ADS-943GM-C	-55 to +125°C	SMT	Yes		
ADS-943G/883	-55 to +125°C	SMT	No		
ADS-943G-C/883	-55 to +125°C	SMT	Yes		