

New SMT Package

FEATURES

- Small 8-pin DIP or SMT package
- 30ns typical acquisition time to $\pm 0.01\%$, 40ns typical acquisition time to 0.005%
- 15ns typical sample-to-hold settling time to $\pm 0.01\%$
- 100MHz small signal bandwidth
- -78dB feedthrough attenuation
- ± 2 picoseconds aperture uncertainty
- 85mW typical, 135mW maximum power dissipation

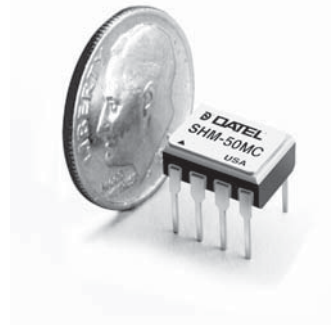

GENERAL DESCRIPTION

DATEL's SHM-50 is a high-speed, highly accurate sample/hold designed for precision, high-speed analog signal processing applications. The SHM-50 features excellent dynamic specifications including a maximum acquisition time of only 40 nanoseconds for a 2V step to $\pm 0.01\%$.

Sample-to-hold settling time, to $\pm 0.01\%$ accuracy, is 20 nanoseconds maximum with an aperture uncertainty of ± 2 picoseconds.

The SHM-50 is a complete sample/hold circuit, containing a precision MOS hold capacitor and a MOSFET switching configuration which results in faster switching and better feedthrough attenuation. Additionally, a FET input amplifier design allows faster acquisition and settling times while maintaining a considerably lower droop rate.

INPUT/OUTPUT CONNECTIONS

Pin	Function
1	+5v Digital Supply
2	S/H Control
3	Analog Input
4	Analog Return
5	-5v Supply
6	Analog Output
7	+5v Analog Supply
8	Power Ground

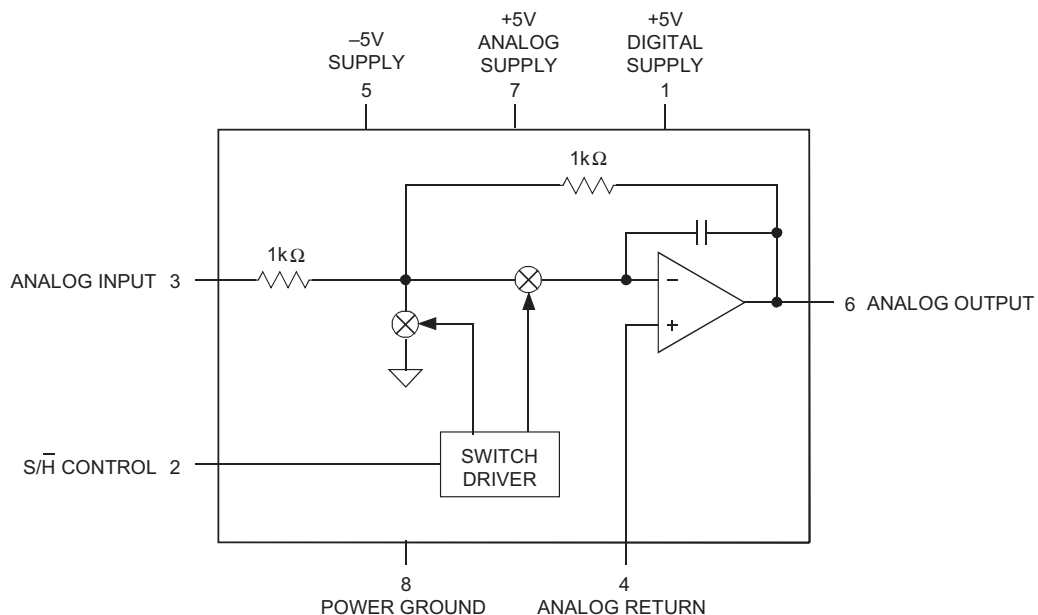

Figure 1. Functional Block Diagram

Absolute Maximum Ratings

$\pm 5V$ Supply Voltages	$\pm 6.6V$
Analog Input	$\pm 4V$
Digital Input	$-0.5V$ to $+5.5V$
Output Current	± 65 mA

Functional Specifications

Apply over the operating temperature range with $\pm 5Vdc$ unless otherwise specified.

ANALOG INPUT/OUTPUT	MIN.	TYP.	MAX.	UNITS
Input/Output Voltage Range	-3.5	—	+3.5	Volts
Input Impedance	—	1000	—	Ω
Output Current	—	—	± 65	mA
Output Impedance	—	0.1	—	Ω
Capacitive Load	100	250	—	pF
DIGITAL INPUT				
Input Logic Levels				
Logic 1	+2.0	—	+5.0	Volts
Logic 0	0	—	+0.8	Volts
Loading				
Logic 1	—	—	+5	μA
Logic 0	—	—	-5	μA
TRANSFER CHARACTERISTICS				
Gain	—	-1	—	V/V
Gain Error, +25°C	—	± 0.05	± 0.25	%
Linearity Error ①	—	± 0.0035	± 0.005	%FS
Sample Mode Offset, +25°C	—	± 2	7	mV
Sample-to-Hold Offset (Pedestal), +25°C ②	—	± 30	60	mV
Gain Drift	—	± 1	± 15	ppm/°C
Sample Mode Offset Drift ①	—	± 3	± 15	ppm of FSR/°C
Sample-to-Hold Off. (Pedestal) Drift	—	± 5	± 20	ppm of FSR/°C
DYNAMIC CHARACTERISTICS				
Acquisition Time				
2V to $\pm 0.005\%$ FS ($\pm 100\mu V$)				
+25°C	—	40	50	ns
-55 to +125°C	—	70	TBD	ns
2V to $\pm 0.01\%$ FS ($\pm 200\mu V$)				
+25°C	—	30	40	ns
-55 to +125°C	—	40	50	ns
2V to $\pm 0.1\%$ FS ($\pm 2mV$)	—	25	30	ns
Sample-to-Hold Settling Time				
2V to $\pm 0.005\%$ FS ($\pm 100\mu V$)	—	15	25	ns
2V to $\pm 0.01\%$ FS ($\pm 200\mu V$)	—	10	20	ns
Sample-to-Hold Transient	—	100	—	mVp-p
Aperture Delay Time	—	2	4	ns
Aperture Uncertainty (Jitter)	—	± 2	± 4	ps
Output Slew Rate	600	± 650	—	V/ μs
Small Signal BW (-3dB)	90	100	—	MHz
Output Droop				
+25°C	—	± 0.2	± 1.0	$\mu V/nS$
0 to +70°C	—	± 0.3	± 1.0	$\mu V/nS$
-55 to +125°C	—	± 5.0	± 12.0	$\mu V/nS$
Feedthrough Rejection	—	-78	—	dB

POWER REQUIREMENTS	MIN.	TYP.	MAX.	UNITS
Voltage Range				
+5V Supply	+4.75	+5.0	+5.25	Volts
-5V Supply	-4.75	-5.0	-5.25	Volts
Power Supply Rejection Ratio	—	± 0.5	± 1	mV/V
Quiescent Current Drain				
+5V Analog Supply	—	+7	+12	mA
-5V Supply	—	-10	-15	mA
Power Consumption	—	85	135	mW
PHYSICAL/ENVIRONMENTAL				
Operating Temp. Range, Case				
SHM-50MC				0 to +70°C
SHM-50MM				-55 to +125°C
Storage Temperature Range				
-65 to +150°C				
Thermal Impedance				
θ_{jc}				15°C/W
θ_{ca}				35°C/W
Package Type	8-pin ceramic DIP or SMT			

Footnotes:

- ① Full Scale (FS) = 2V. Full Scale Range (FSR) = 4V.
- ② Sample-to-hold offset error (pedestal) is constant regardless of input/output level.

Ordering Information

MODEL	OPERATING TEMP. RANGE	PACKAGE
SHM-50MC	0 to +70°C	DIP
SHM-50MM	-55 to +125°C	DIP
SHM-50GC	0 to +70°C	SMT
SHM-50GM	-55 to +125°C	SMT

For availability of high-reliability versions of the SHM-50, contact DATEL.

TECHNICAL NOTES

1. All ground pins should be tied together and connected to system analog ground as close to the package as possible. It is recommended to use a ground plane under the device and solder ground pins directly to it. Take care to ensure that no ground potentials can exist between ground pins. A single +5V supply can be used for both +5V Digital Supply (pin 1) and +5V Analog Supply (pin 7).
2. External 0.1 μF to 4.7 μF tantalum bypass capacitors are required in critical applications.
3. A logic 1 on S/H puts the unit in the sample mode. A logic 0 puts the unit in hold mode.
4. Gain and offset adjusting can be accomplished using the external circuitry shown in Figure 2. Adjust offset with a 0V input. Adjust gain with a $\pm FS$ input. Adjust so that the output in the hold mode matches the input.

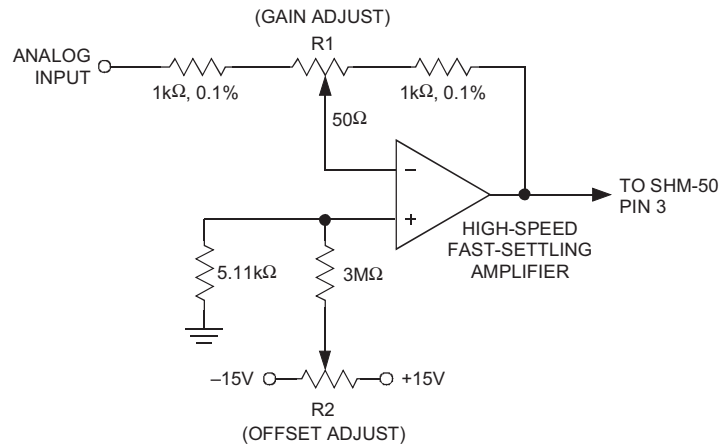
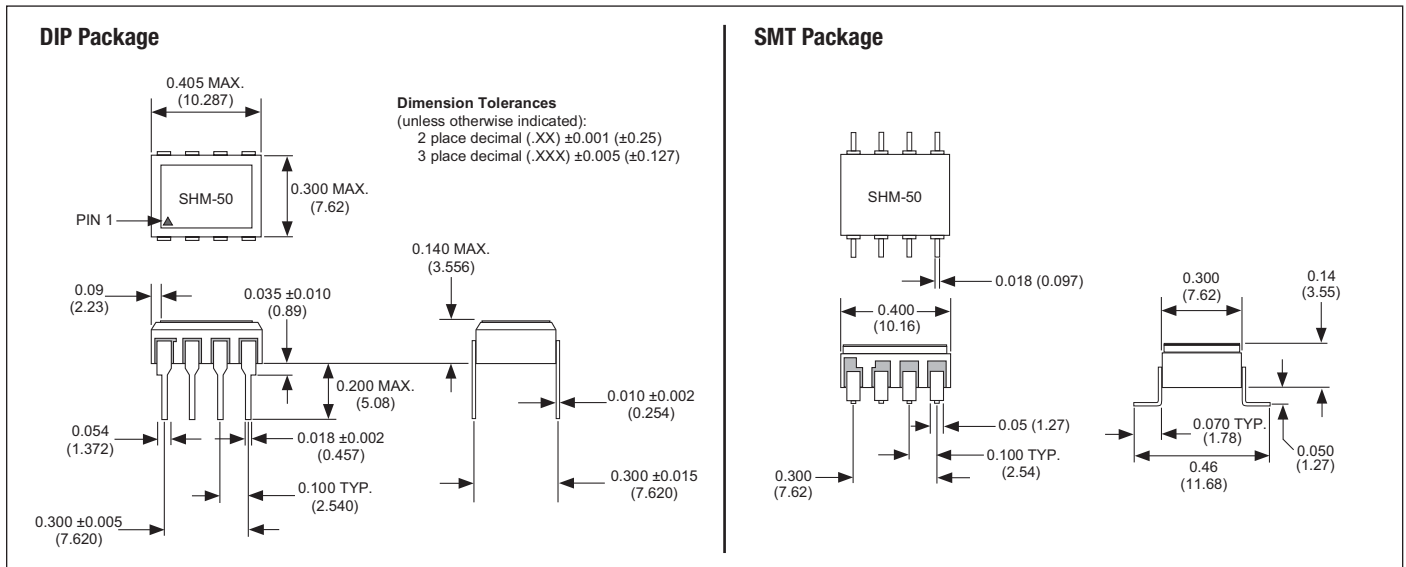

Figure 2. Offset and Gain Adjustments

MECHANICAL DIMENSIONS Inches (mm)



ISO 9001
REGISTERED

DATEL is a registered trademark of
Murata Power Solutions, Inc.
11 Cabot Boulevard, Mansfield, MA 02048-1151 USA
ITAR and ISO 9001/14001 REGISTERED

Murata Power Solutions, Inc. makes no representation that the use of its products in the circuits described herein, or the use of other technical information contained herein, will not infringe upon existing or future patent rights. The descriptions contained herein do not imply the granting of licenses to make, use, or sell equipment constructed in accordance therewith. Specifications are subject to change without notice.

© 2011 Murata Power Solutions, Inc.

www.datel.com • e-mail: help@datel.com