

2000 RPM Tachometer

General Description

The circuit shown in the figure below will have a display reading of "1999" for an input frequency of 33.33Hz (equivalent to 1999 rpm). The 0.047µF capacitor (C1) should have a low-temperature-coefficient dielectric (polyester, polycarbonate and polypropylene are adequate for most applications). The 47µF capacitor (C2) is used to reduce the output ripple of the LM2917. If this value is made too large, the output ripple will be smaller, however, the response time of the LM2917 output (pin 3), for a given change in F_{IN} , will be longer. The 50k multi-turn potentiometer allows for overall calibration of the circuit's output at 1999 rpm. All fixed resistors should be metal-film types for good temperature stability.

Theory of Operation

The equation below is used to determine the LM2917's output voltage (pin 3) which is connected to the DMS-30PC's (+) INPUT HI terminal (assume the 50k potentiometer is set to 0Ω):

$$V_{OUT} = (R1 + R2) (V_{CC}) (C1) (F_{IN})$$

$$V_{OUT} = (150 \times 10^3) (7.5) (47 \times 10^{-9}) (33.33) = 1.762Vdc$$

The 50k potentiometer is adjusted so the meter's display reads "1999" at 1999 RPM.

The differential inputs of the LM2917 (pins 1 and 11) give the user the option of setting the input signal triggering level while still maintaining hysteresis around that point for noise rejection. In this example, this function is achieved with the 10kΩ and 200Ω resistor divider (R4 and R5). Pins 1 and 11 of the LM2917 should not be taken below ground or above the supply voltage on pin 9 (+7.5V).

To ensure proper input frequency sensing, the voltage applied to pin 11 of the LM2917 should be at least 100mV above the lowest input voltage normally applied to pin 1 (F_{IN}). Please refer to the LM2917 data sheet (available from National Semiconductor) for more information.

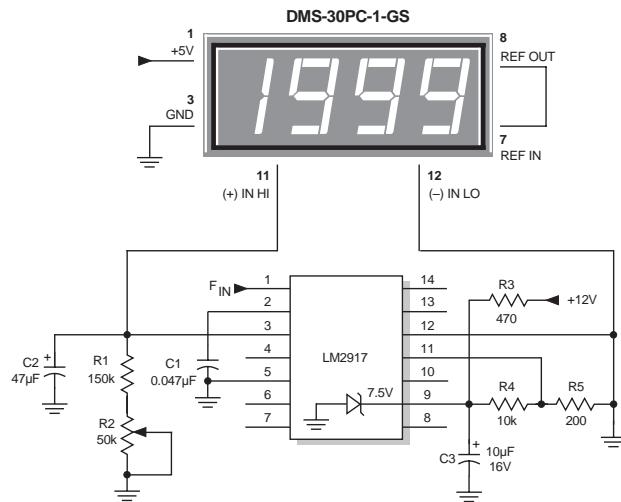

Figure 1. 0-1999 RPM Tachometer Circuit