

PRODUCT OVERVIEW

DATEL's PM-35LC-ADV series of adjustable voltage-input digital process meters' design makes them ideal replacements for many OEM panel meters found in industrial applications. Key features are a small panel cutout of 2.4" x 1.0", 0.45" high-contrast, 3½ digit LCD display, and three adjustment potentiometers. All models operate from industry standard 24Vdc (@40mA, max.) and include a snap-in bezel that allows for quick setup and installation.

All input signal and power connections are made via reliable screw-style terminal blocks. Three, 25-turn precision potentiometers provide individual adjustment of gain (span) and offset (zero). The 0-5V and 0-10V input ranges both support adjustment of differential ranges (i.e., highest reading minus the lowest reading) from "10" to "1999". These two ranges also support an offset adjustment range of ±1800 counts. A fixed-gain input range of 0-200mVdc provides additional signal conditioning flexibility.

Standard models are supplied with four user-selectable annunciators for displaying Volts ("V"); Amps ("A"); kilowatts ("kW"); or percent ("%"). Optional models can be configured to display degrees Celsius ("°C") or Fahrenheit ("°F"); pounds per square inch ("PSI"); or percent ("%"). PC-board style jumpers simplify user selection of input signal range, decimal point position, and engineering unit annunciators.

FEATURES

- Low-cost Replacement for OEM Process DPMs
- 3½ Digit, High Contrast, 0.45 inch (11.4mm) Green LCD Display
- Three Input Ranges: 0–±200mV; 0–±5V; and 0–±10V
- 25-Turn Gain, Span, and Offset Potentiometers
- Differential Readings Adjustable from 10 to 1999
- Miniature 2.5 x 1.1 Inch Package (64 x 28mm)
- Screw-Terminals for Power and Input Connections
- Easy Snap-in Bezel Simplifies Panel Mounting
- Operates From Single 24Vdc Regulated Power
- Standard °C; °F; PSI; or % Annunciators
- Optional Annunciators for Volts; Amps; kW; or PF
- User Selectable Decimal Points and Engineering Units

All models feature an input impedance of 390kOhm (typ.) to minimize signal loading, 3 conversions/second, and a typical accuracy of ±0.1% of full scale, ±2 counts. All models are specified to operate over a temperature range of 0 to +50°C (+122°F).

APPLICATIONS:

- Process Monitoring
- Test and Measurement
- Replacement for OEM Panel Meters
- Engineering Scaling

AVAILABLE OPTIONS

- Annunciators for dc or ac power monitoring
- Regulated 120Vac to 24Vdc Power Supply

FUNCTIONAL BLOCK DIAGRAM

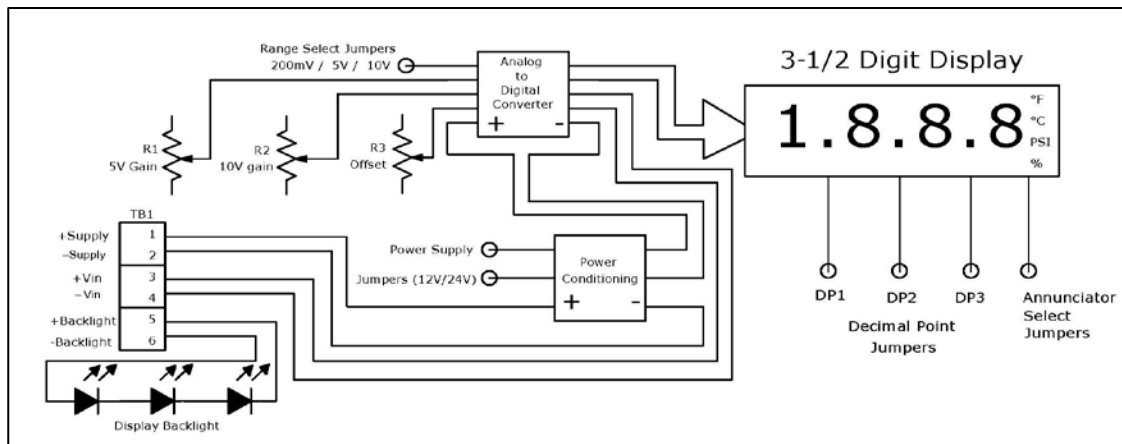

Specifications and Performance

Typical at 25°C and 24Vdc power supply input unless otherwise noted

Parameters	Conditions	Model	Min.	Typical	Max.	Units
Full Scale Range (Vin) ①	DC Voltage	All	0.2	5.0	10	Vdc
Input Impedance		All	390	–	–	kΩ
Overvoltage Capability	Dc Voltage	All	–	–	±20	Vdc
Input Type ②	Single-ended connection, see Note 2					
Electrical Performance						
Display Update Rate	3 readings per second					
Accuracy (10 minute warmup):	±0.1% FS ±2 Counts					
Temperature Drift (0 to +60°C)	PPM		–	±100	–	PPM/°C
Power Supply Requirements ③						
Non-Backlit Models (10mA max)	Regulated		+12	—	+24	Vdc
Backlight Power Supply (40mA max)	Regulated		–	24	–	±2Vdc
Display						
Display Type and Size	LCD, 3½ digits (±1999), 0.45" [11.4mm] mm high. See ordering guide for available colors and backlight options					
Polarity	Negative sign ("–") for negative inputs					
Over-range Reading	"–1---" for negative Vin; "1---" for positive Vin					
Decimal Points	3 user-selectable positions					
Offset Range	-1700 to +1700 counts					
Differential Gain Range	10-1999 counts above adjusted zero reading					
Annunciators	°C, °F, PSI, %; or V, A, KW, PF (see ordering guide)					
Environmental						
Operating Range		All	0	–	+50	°C
Storage Range		All	–10	–	+60	°C
Panel Mounting	Snap-in bezel mount					
Input and Supply Connections	4-position terminal block (6 for backlit models)					
Unit Weight	1.3 ounces (37 grams)					

Notes:

- All units can be user configured to accept the following three input ranges: 0 to ±200mVdc; 0 to ±5.0Vdc; and 0 to ±10.0Vdc. Refer to operating and setup instructions for more information.
- Units can only accept single-ended inputs, where the negative terminal of the input voltage (–Vin) is connected to power supply ground (–Supply).
- Backlit models contain locations for connecting 24Vdc to supply power for the display's backlighting circuit and display-driver electronics. Backlit models can theoretically be powered from two separate isolated power sources: either 12 or 24Vdc to supply operating power (TB1-1 and TB1-2), and 24Vdc to supply backlighting power (TB1-5 and TB1-6). **Important:** for proper meter operation, the negative terminal of the 12V and/or 24V power supplies and the negative terminal of the input signal must be externally shorted together (i.e., at a common potential). Refer to the following sections describing connections and setup for detailed instructions.

Input Signal and Power Connection Characteristics

1. Input signal: TB1, terminals 3 (+Vin) and 4 (-Vin) have an input impedance of approximately 390kΩ. In most applications, this impedance is sufficiently high to not reduce or alter the input signal level.

Important: As shipped, -Vin (TB1-4) is not connected to -SUPPLY (TB1-2). The user must externally provide a connection from -Vin to -SUPPLY for proper operation. For optimum display stability and accuracy, this connection should be made directly at—or as close as possible to—terminal block TB1.

PM-35LC-ADV meters have three user-selectable input ranges as follows: 0-200mVdc, 0-5Vdc, and 0-10Vdc. The 0-5Vdc and 0-10Vdc ranges' gain can both be adjusted using potentiometers R1 and R2. **The 0-200mVdc range's gain is internally fixed and cannot be adjusted by the user.** However, zero offset potentiometer R3 will affect the meter's zero display reading on all three input ranges.

2. Power Supply Connections: On models with backlit displays (see ordering guide), TB1 terminals 1 (+SUPPLY) and 2 (-SUPPLY), and TB1 terminals 5 (+Backlite) and 6 (-Backlite) must be connected to a regulated and filtered 24Vdc power supply. In single supply installations, -Backlite can be connected to -Supply directly at TB1.

Please note, some dc power supplies will not operate correctly when powering low-current devices like PM-35LC-ADV series meters. That is, these power supplies specify a minimum load to guarantee a regulated, low-noise output.

3. Fusing Requirements: PM-35LC-ADV meters do not contain internal fusing for both the operating power supply and the backlighting supply. In order to protect the meter itself and any associated external systems, DATEL recommends connecting one external 0.25A/250V time delay/time lag fuse in series with TB1-1 (+Supply) and TB1-5 (+Backlite) on backlit models.

4. TB1 Terminal Block Ratings: TB1 will accept solid or stranded copper wires in the range of 18-22AWG, with 0.25 inches of insulation stripped off at connection point. TB1 terminals should be torque to approximately 3.5lbf-in (0.4Nm).

Pre-Operational Setup:

!!CAUTION!! To ensure operator safety, all jumper settings must be made before power and input signal connections are made to terminal block TB1. Disregarding this precaution may subject the user to potentially dangerous electrical potentials and may adversely affect the meter's operation and long-term reliability. Setup of PM-35LC-ADV meters must only be performed by qualified technical personnel.

1. **Power Supply Jumper Settings:** Refer to Figure 2 to select the correct jumper configuration for for the unit's operating power supply. Figure 2 shows the meter configured for +24Vdc operation. Jumper J1's setting is only used to select the power source that powers the meter's electronics. Jumper J1 has no effect on backlit models' power source since the backlighting power supply must always be 24Vdc (± 2 Vdc) and connected to TB1-5 and TB1-6.

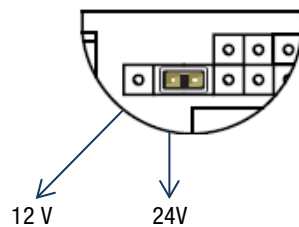

Figure 2: J1 Power Supply Selection (12V/24V)

2. **Input Range Jumper Settings:** Refer to Figure 3 and set jumper J2 for the desired full-scale input range. Figure 3 is shown with the meter configured for 0-200mVdc input range.

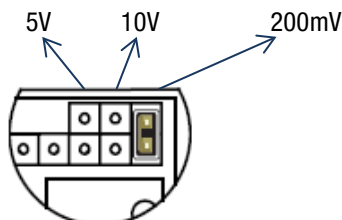

Figure 3: J2 Input Range Selection (5V/10V/200mV)

3. Decimal Point Selection Jumper Settings: Refer to Figure 4 to select which decimal point (if any) needs to be illuminated for the chosen application. If no decimal is needed, do not install jumpers in any of these three locations. Please note, decimal point selection has no effect on the meter's operation, gain offset adjustments, or resolution/sensitivity of the meter's analog to digital conversion circuitry. Illuminated decimal points only serve as visual placeholders to show correct display readings of the physical parameter being measured.

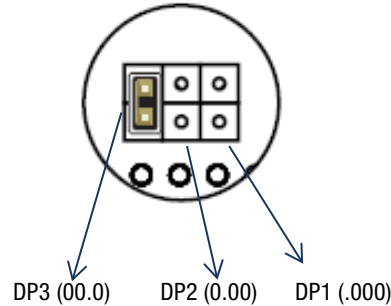

Figure 4: J3 Decimal Point Selection

4. Annunciator Jumper Settings: As shown in Figure 5, four annunciator jumpers are located on the back of the meter module. On standard models shown in the ordering guide, these jumpers allow for illumination of one of four display annunciators as follows: °C; °F; PSI; or %. Optionally, annunciators are available for Volts, Amps, kW, or Power Factor (V; A; kW, or PF); please contact DATEL for availability. To disable all annunciators, simply leave all four jumpers open (i.e., not installed).

Figure 5 shows jumper configuration for illuminating the °F symbol annunciator.

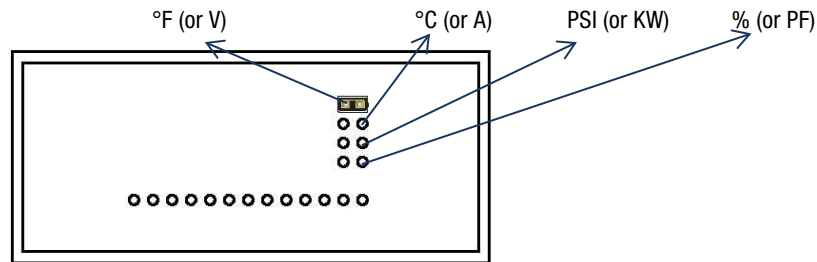
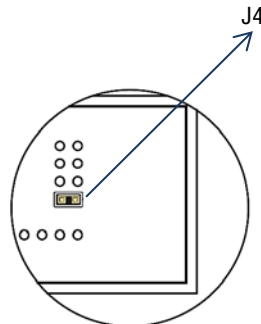

Figure 5: J4 Annunciator Selection (backside of meter itself)

Setup Examples

1. A 0-5Vdc process input is required to show display readings of 0 to 100% with no decimal point:

- a. With all power and input wiring disconnected from TB1, carefully remove the backboard assembly and enable the “%” annunciator on the back of the meter module by closing Jumper J4. Observing correct orientation, carefully align and re-attach the backboard to the meter module.



- b. Configure jumper J2 for the 0-5Vdc range.

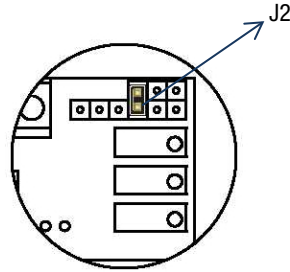

- c. Ensure the power selection jumper has been set according to the supply voltage and model in use.
 d. Connect power and signal to TB1 (and also backlit power if applicable) and then energize the power and signal sources.
 e. Apply 0.0Vdc and adjust offset potentiometer R3 so the display reads "000".
 f. Apply 5.0Vdc and adjust 5V gain potentiometer R1 so the display reads "100".

No decimal point was required for this example so no decimal point selection jumper is installed.

2. A 0-10V process input is required to show display readings of 10.0 to 30.0PSI:

- a. With all power and input wiring disconnected from TB1, carefully remove the backboard assembly and enable the "PSI" annunciator on the back of the meter module by closing Jumper J4

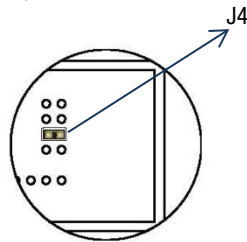

Observing correct orientation, carefully align and re-attach the backboard to the meter module.

- b. Configure jumper J2 for the 0-10Vdc range.

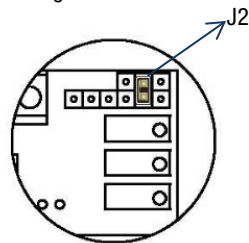

- c. Ensure the power selection jumper has been set according to the supply voltage and model in use.
 d. Enable decimal point DP3 by installing jumper J3.

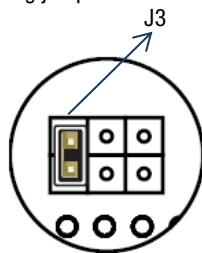

- e. Connect power and signal to TB1 (and backlit power if applicable) and then energize the power and signal sources.
 f. Apply 0Vdc and adjust R3 so the display reads "00.0".
 g. Apply 10Vdc and adjust 10V gain potentiometer R2 so the display reads a differential reading of "20.0".
 h. Apply 0Vdc and adjust R3 so the display reads "10.0".
 i. Re-apply 10Vdc and check that the display now reads "30.0".

WIRE CONNECTIONS

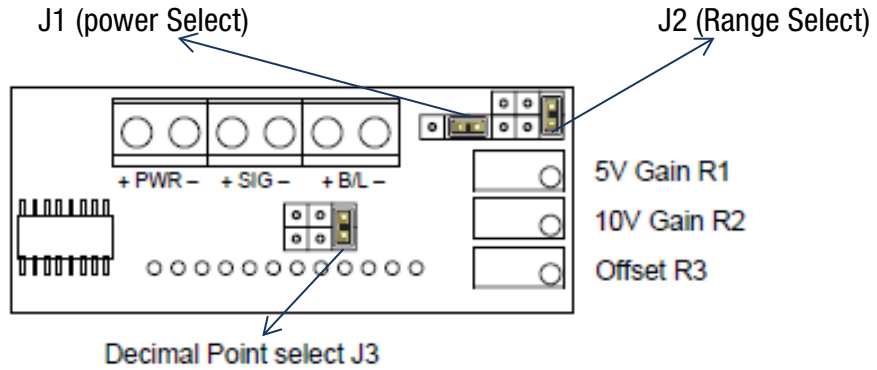

MECHANICAL DIMENSIONS Inches (mm)

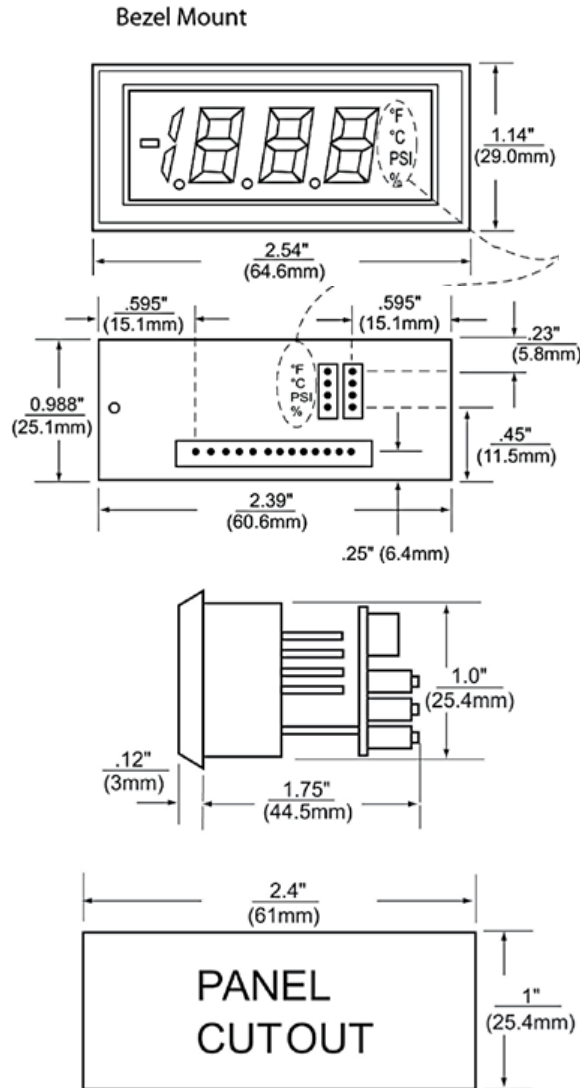

Note: All dimensions are in inches (millimeters). Tolerance: x.xx ±0.02 in. (0.5mm), x.xxx ±0.010 in. (0.25 mm) unless otherwise noted

PART NUMBERING AND ORDERING INFORMATION

PART NUMBER	DISPLAY TYPE	ANNUNCIATORS	POWER SUPPLY
PM-35LC-ADV-01	3.5 Digit LCD Backlit Green*	V, A, kW, PF	24Vdc
PM-35LC-ADV-02	3.5 Digit LCD Backlit Green*	°C, °F, PSI, %	24Vdc
PM-35LC-ADV-03	3.5 Digit LCD No Backlight**	V, A, kW, PF	12 or 24Vdc
PM-35LC-ADV-04	3.5 Digit LCD No Backlight**	°C, °F, PSI, %	12 or 24Vdc

* Backlit models have green segments on a black background

** Non-backlit models have black segments on a silver background

Accessories:

PW2-24 120Vac to 24Vdc Power Supply