



PRODUCT OVERVIEW

The PT series offers 3 watt of isolated output power in an 8 pin SIP standard package. These converters have a 2:1 wide input voltage range of 4.5 to 9, 9 to 18, 18 to 36 or 36 to 75 Volts. This series of converters provides precise regulated output voltage ranging from 3.3 to 15 volts. The output voltage can be single or dual depending on the model. Other output voltages are also available and please contact DATEL if your application requires such modification.

This series features high efficiency up to 86%; 1500Volts of DC of isolation and can operate over the ambient temperature range of -40°C to +70°C without derating. These modules are fully protected against output short circuit and under overvoltage conditions.

FEATURES

- Industry Standard SIP 8 Package
- 3 Watts Isolated Output
- 2:1 Input Range
- Regulated Outputs
- Up to 86 % Efficiency
- -40°C to +85 operating temperature range
- Remote On/Off logic control
- Continuous Short Circuit Protection
- Under Voltage protection
- Meets 2004/108/EC
- Safety designed to meet UL60950-1, EN60950-1, and IEC60950-1

APPLICATIONS:

- Distributed Power Architectures
- Mobile telecommunication
- Industrial applications
- Battery operated equipment

AVAILABLE OPTIONS

- Customizable Input/ Output voltages
- UL/CSA60950-1, TUV per IEC/ EN60950-1, 2nd Edition

Contact DATEL for other series in SIP Package

- 4:1 Input Ranges
- Cost saving, lower / higher power, other output voltages etc.

BLOCK DIAGRAM

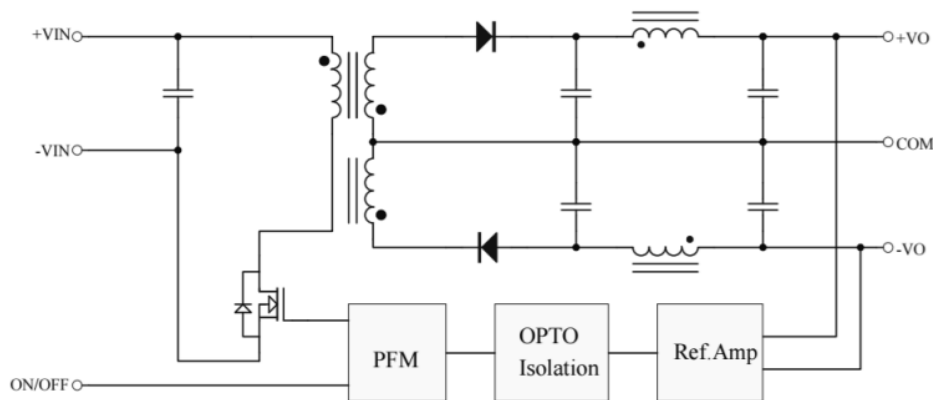

MODEL DESIGNATIONS

MODEL NUMBER	INPUT VOLTAGE	OUTPUT VOLTAGE	OUTPUT CURRENT MAX	EFFICIENCY %	LOAD REGULATION	LINE REGULATION
PT5S3.3-0.7	4.5-9V	3.3VDC	700 mA	73	± 0.5 %	0.5%
PT5S5-0.6	4.5-9V	5.0 VDC	600 mA	78	± 0.5 %	0.5%
PT5S12-0.25	4.5-9V	12 VDC	250 mA	81	± 0.5 %	0.5%
PT5S15-0.2	4.5-9V	15 VDC	200 mA	81	± 0.5 %	0.5%
PT5D5-.3	4.5-9V	±5.0 VDC	±300 mA	78	± 1 %	0.5%
PT5D12-0.12	4.5-9V	±12 VDC	±125 mA	81	± 1 %	0.5%
PT5D15-0.1	4.5-9V	±15 VDC	±100 mA	81	± 1 %	0.5%
PT12S3.3-0.7	9-18V	3.3VDC	700 mA	76	± 0.5 %	0.5%
PT12S5-0.6	9-18V	5.0 VDC	600 mA	81	± 0.5 %	0.5%
PT12S12-0.25	9-18V	12 VDC	250 mA	83	± 0.5 %	0.5%
PT12S15-0.2	9-18V	15 VDC	200 mA	84	± 0.5 %	0.5%
PT12D05-0.3	9-18V	±5.0 VDC	±300 mA	82	± 1 %	0.5%
PT12D12-0.12	9-18V	±12 VDC	±125 mA	83	± 1 %	0.5%
PT12D15-0.1	9-18V	±15 VDC	±100 mA	84	± 1 %	0.5%
PT24S3.3-0.7	18-36V	3.3VDC	700 mA	77	± 0.5 %	0.5%
PT24S05-0.6	18-36V	5.0 VDC	600 mA	81	± 0.5 %	0.5%
PT24S12-0.25	18-36V	12 VDC	250 mA	84	± 0.5 %	0.5%
PT24S15-0.2	18-36V	15 VDC	200 mA	85	± 0.5 %	0.5%
PT24D05-0.3	18-36V	±5.0 VDC	±300 mA	80	± 1 %	0.5%
PT24D12-0.12	18-36V	±12 VDC	±125 mA	84	± 1 %	0.5%
PT24D15-0.1	18-36V	±15 VDC	±100 mA	85	± 1 %	0.5%
PT48S3.3-0.7	36-75V	3.3VDC	700 mA	77	± 0.5 %	0.5%
PT48S05-0.6	36-75V	5.0 VDC	600 mA	81	± 0.5 %	0.5%
PT48S12-0.25	36-75V	12 VDC	250 mA	86	± 0.5 %	0.5%
PT48S15-0.2	36-75V	15 VDC	200 mA	86	± 0.5 %	0.5%
PT48D05-0.3	36-75V	±5.0 VDC	±300 mA	81	± 1 %	0.5%
PT48D12-0.12	36-75V	±12 VDC	±125 mA	86	± 1 %	0.5%
PT48D15-0.1	36-75V	±15 VDC	±100 mA	86	± 1 %	0.5%

ABSOLUTE MAXIMUM RATINGS

PARAMETER	CONDITIONS	MODEL	Min.	Typical	Max.	Units
Input Voltage						
Continuous	DC	5V _{in}	4.7		9	Volts
		12V _{in}	9		18	
		24V _{in}	18		36	
		48V _{in}	36		75	
Transient	100ms, DC	5V _{in}			15	Volts
		12V _{in}			25	
		24V _{in}			50	
		48V _{in}			100	
Operating Ambient Temperature	Derating, Above 70°C	All	-40		+85	°C
Case Temperature		All			+100	°C
Storage Temperature		All	-55		+125	°C
Input / Output Isolation Voltage	1 minute	All			1500	Volts

INPUT CHARACTERISTICS

Note: All specifications are typical at nominal input, full load at 25°C unless otherwise noted

PARAMETER	CONDITIONS	MODEL	Min.	Typical	Max.	Units
Operating Input Voltage		5V _{in}	4.5	5	9	Volts
		12V _{in}	9	12	18	
		24V _{in}	18	24	36	
		48V _{in}	36	48	75	
Input Under Voltage Lockout						
Turn-On Voltage Threshold		5V _{in}	3.3	4.0	4.2	Volts
		12V _{in}	6.8	7.0	7.3	
		24V _{in}	13	14.7	15.5	
		48V _{in}	26	28.5	31	
Turn-Off Voltage Threshold		5V _{in}	3	3.5	3.9	Volts
		12V _{in}	5.8	6	6.3	
		24V _{in}	12	13	14.5	
		48V _{in}	24	30	33	
Lockout Hysteresis Voltage		5V _{in}		0.3		Volts
		12V _{in}		5		
		24V _{in}		1		
		48V _{in}		2		
Maximum Input Current	100% Load, V _{in} = 4.5V	5V _{in}			890	mA
	100% Load, V _{in} = 9V	12V _{in}			440	
	100% Load, V _{in} = 18V	24V _{in}			220	
	100% Load, V _{in} = 36V	48V _{in}			110	
No-Load Input Current	V _{in} = Nominal input	PT5S3.3-0.7		60		mA
		PT5S5-0.6		60		
		PT5S12-0.25		60		
		PT5S15-0.2		60		
		PT5D5-0.3		60		
		PT5D12-0.12		60		
		PT5D15-0.1		60		
		PT12S3.3-0.7		30		
		PT12S5-0.6		30		
		PT12S12-0.25		30		
		PT12S15-0.2		30		
		PT12D5-0.3		30		
		PT12D12-0.12		30		
		PT12D15-0.1		30		
		PT24S3.3-0.7		18		
		PT24S5-0.6		18		
		PT24S12-0.18		18		
		PT24S15-0.2		18		
		PT24D5-0.3		18		
		PT24D12-0.12		18		
PT24D15-0.1		18				
PT48S3.3-0.7		9				
PT48S5-0.6		9				
PT48S12-0.25		9				
PT48S15-0.2		9				
PT48D5-0.3		9				
PT48D12-0.12		9				
PT48D15-0.1		9				
Inrush Current (I ² t)	As per ETS300 132-2	All			0.01	A ² s
Off Converter Input Current	Shutdown input idle current	All			1	mA
Input Reflected-Ripple Current	P-P thru 12μH inductor, 5Hz to 20MHz	All		30		mA

OUTPUT CHARACTERISTIC

PARAMETER	CONDITIONS	MODEL	Min.	Typical	Max.	Units
Output Voltage Set Point	$V_{in} = \text{Nominal } V_{in}, I_o = I_{o_max}, T_c = 25^\circ\text{C}$	$V_o = 3.3$	3.2505	3.3	3.3495	Volts
		$V_o = 5.0$	4.925	5	5.075	
		$V_o = 12$	11.82	12	12.18	
		$V_o = 15$	14.775	15	15.225	
		$V_o = \pm 5.0$	4.925	5	5.075	
		$V_o = \pm 12$	11.82	12	12.18	
		$V_o = \pm 15$	14.775	15	15.225	
Output Voltage Regulation						
Line Regulation	$V_{in} = \text{High line to Low line Full Load}$	Single Dual			± 0.5 ± 0.5	% %
Load Regulation	$I_o = \text{Full Load to min. Load}$	Single Dual			± 0.5 ± 1	% %
Cross Regulation	Load cross variation 10%/100%	Dual			± 5	%
Temperature Coefficient	$T_c = -40^\circ\text{C to } +85^\circ\text{C}$				± 0.03	%/ $^\circ\text{C}$
Output Voltage balance	$V_{in} = \text{Nominal } V_{in}, I_o = I_{o_max}, T_c = 25^\circ\text{C}$	Dual			± 1	%
Output Voltage Ripple and Noise						
Peak-to-Peak	Full Load, 20 MHz	Single			75	mV
		Dual			75	
Operating Output Current Range		$V_o = 3.3\text{V}$	0		700	mA
		$V_o = 5\text{V}$	0		600	
		$V_o = 12\text{V}$	0		250	
		$V_o = 15\text{V}$	0		200	
		$V_o = \pm 5\text{V}$	0		± 300	
		$V_o = \pm 12\text{V}$	0		± 125	
		$V_o = \pm 15\text{V}$	0		± 100	
Output DC Current-Limit Inception	Output Voltage = 90% $V_{o_nominal}$			120		%
Maximum Output Capacitance	Full load, Resistance	$V_o = 3.3\text{V}$			700	μF
		$V_o = 5\text{V}$			600	
		$V_o = 12\text{V}$			250	
		$V_o = 15\text{V}$			200	
		$V_o = \pm 5\text{V}$			300	
		$V_o = \pm 12\text{V}$			125	
		$V_o = \pm 15\text{V}$			100	

DYNAMIC CHARACTERISTICS

PARAMETER	CONDITIONS	MODEL	Min.	Typical	Max.	Units
Output Voltage Current Transient						
Step Change in Output Current	75% to 100% of I_{o_max}	All			± 6	%
Setting Time (within 1% $V_{o_nominal}$)	$di/dt = 0.1\text{A}/\mu\text{s}$	All			500	μs
Turn-On Delay and Rise Time						
Turn-On Delay Time, From On/Off Control	$V_{on/off}$ to 10% V_{o_set}	All		1		ms
Turn-On Delay Time, From Input	V_{in_min} to 10% V_{o_set}	All		1		ms
Output Voltage Rise Time	10% V_{o_set} to 90% V_{o_set}	All		2.5		ms

FEATURE CHARACTERISTICS

PARAMETER	CONDITIONS	Device	Min.	Typical	Max.	Units
Efficiency 100% Load	Vin =5 Volts, Io = Io_max, Tc=25°C	PT5S3.3-0.7		73		%
		PT5S5-0.6		78		
		PT5S12-0.25		81		
		PT5S15-0.2		81		
		PT5D5-0.3		78		
		PT5D12-0.12		81		
		PT5D15-0.1		81		
	Vin =12 Volts, Io = Io_max, Tc=25°C	PT12S3.3-0.7		76		
		PT12S5-0.6		81		
		PT12S12-0.25		83		
		PT12S15-0.2		84		
		PT12D5-0.3		82		
		PT12D12-0.12		83		
	Vin =24 Vdc, Io = Io_max, Tc=25°C	PT24S3.3-0.7		77		
		PT24S5-0.6		81		
		PT24S12-0.25		84		
		PT24S15-0.2		85		
		PT24D5-0.3		80		
		PT24D12-0.12		84		
	Vin =48 Vdc, Io = Io_max, Tc=25°C	PT24D15-0.1		85		
PT48S3.3-0.7			77			
PT48S5-0.6			81			
PT48S12-0.25			86			
PT48S15-0.2			86			
PT48D5-0.3			81			
PT48D12-0.12			86			
PT48D15-0.1		86				
ISOLATION CHARACTERISTICS						
Input to Output	1 minutes	All	1500			Volts
Isolation Resistance		All	1000			MΩ
Isolation Capacitance		All		500		pF
Switching Frequency				100		KHz
On/Off Control, Positive Remote On/Off logic						
Module On	V _{on/off} at I _{on/off} =0.1uA	All	0	0	1.2 or Open Circuit	Volts
Module Off	V _{on/off} Pin	All	5.5		+15	Volts
On/Off Control, Option Under Voltage Control		All		0.3	1	mA
Module On	Open, High impedance		0		0.8 or open circuit	Volts
Module Off	V Remote On/Off Pin		4		+15	Volts
Off Converter Input Current	Shutdown input idle current				1	mA
MTBF	I _o =100%of I _{o_max} ; Ta=25°C per MIL-HDBK-217F	All		2.5		M hours
Weight		All		4.8		grams

Operating Temperature Range

The PT series converters operate over the wide ambient temperature range from -40°C to +85°C. Derating for this series starts above the temperature of +70°C. For normal operation, the case temperature should not go over +100°C.

Remote On/Off

The remote ON/OFF input feature of the converter allows external circuitry to turn the converter ON or OFF. Active-high Remote ON/OFF is available as standard. The converter is turned on if the Remote ON/OFF pin is high impedance or open circuit. Converter with added Suffix "U" to the model number are on with voltage below 0.8 volts at Remote ON/OFF pin and are off when the voltage at Remote ON/OFF pin is from 4 to 15 Volts. All other standard models turn the converter off when the signal at Remote ON/OFF is from 5.5 to 15Vdc. The signal level of the on/off pin is defined with respect to ground. If not using the on/off pin, leave the pin open (module will be on).

Over Current Protection

All models have internal over current and continuous short circuit protection. The unit operates normally once the fault condition is removed. At the point of current limit inception, the converter will go into hiccup mode protection.

Recommended PCB Layout/Footprints and Soldering Information

The user must ensure that other components and metal in the vicinity of the converter meet the spacing requirements to which the system is approved. Low resistance and low inductance PCB layout should be used where possible. Proper attention must also be given to low impedance tracks between power module, input and output grounds. The recommended footprints and soldering profiles are shown in the next two figures.

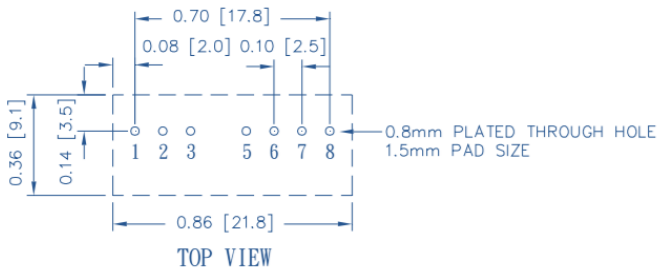

Recommended PCB Layout Footprints

Note: Dimensions are in inches (millimeters)

Lead Free Wave Soldering Profile

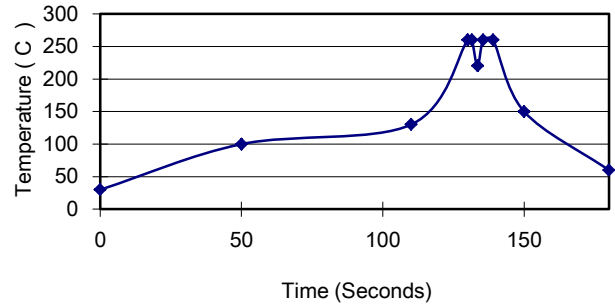

Recommended Wave Soldering Profiles

Note :

1. Soldering Materials: Sn/Cu/Ni
2. Ramp up rate during preheating: 1.4 °C/Sec (From +50°C to +100°C)
3. Soaking temperature: 0.5 °C/Sec (From +100°C to +130°C), 60 ± 20 seconds
4. Peak temperature: +260°C, above +250°C 3~6 Seconds
5. Ramp up rate during cooling: -10.0 °C/Sec (From +260°C to +150°C)

Power De-Rating Curves for PT Series

Note that operating ambient temperature range is -40°C to + 85°C with derating above 71°C. Also, the maximum case temperature under any operating condition should not exceed +100°C.

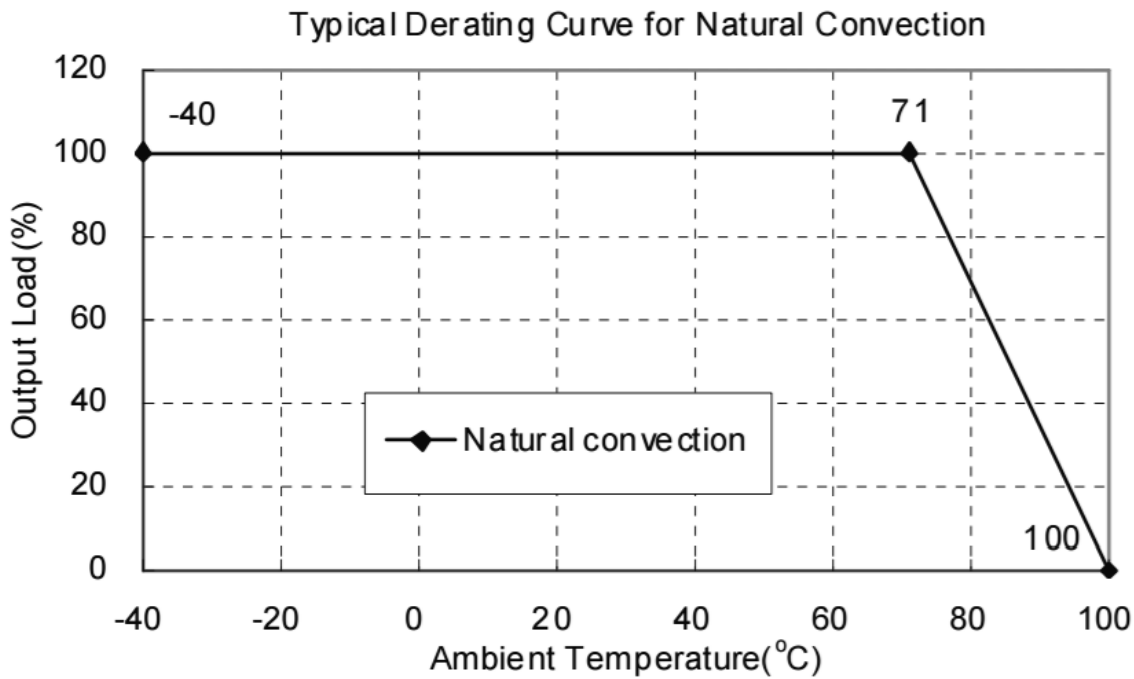

Efficiency vs. Load Curves

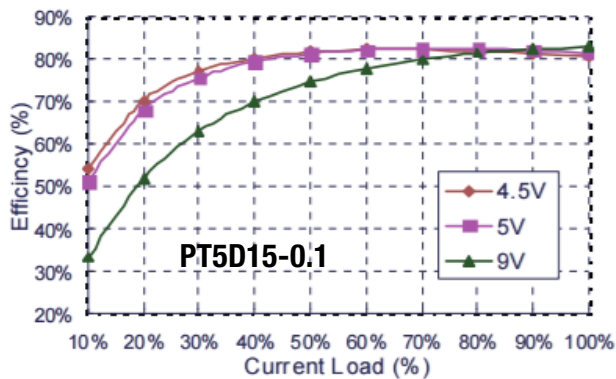
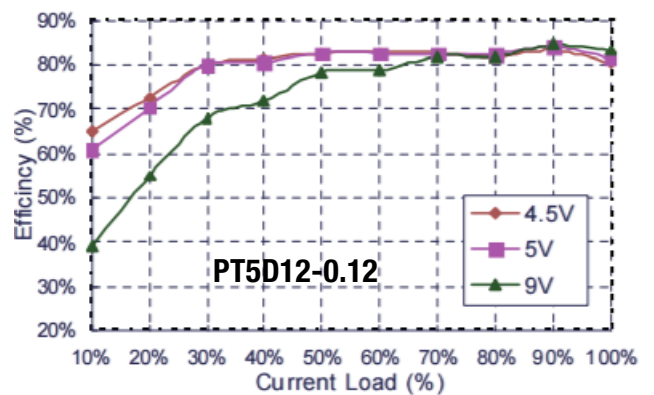
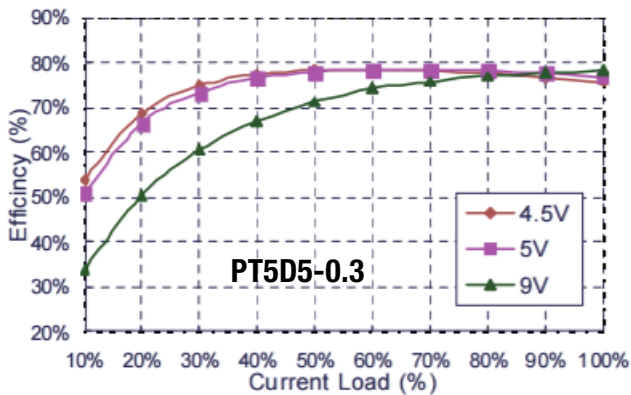
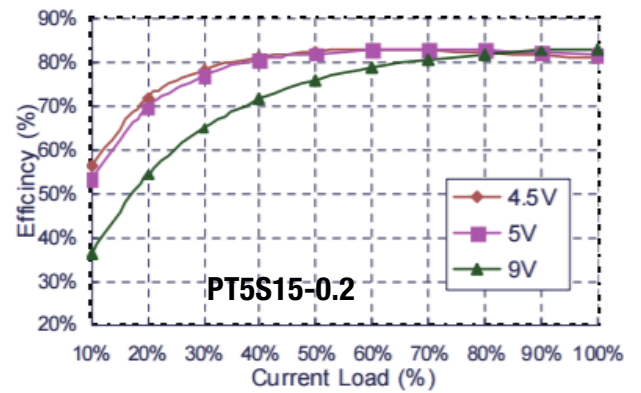
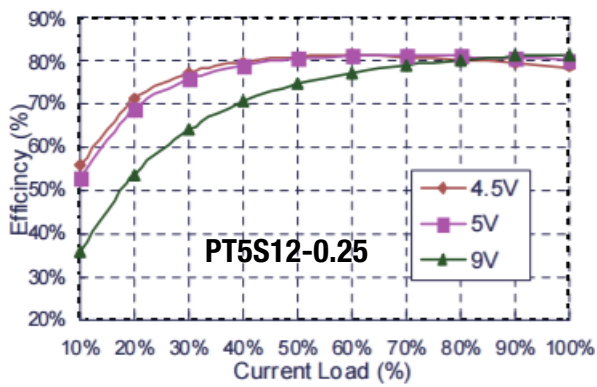
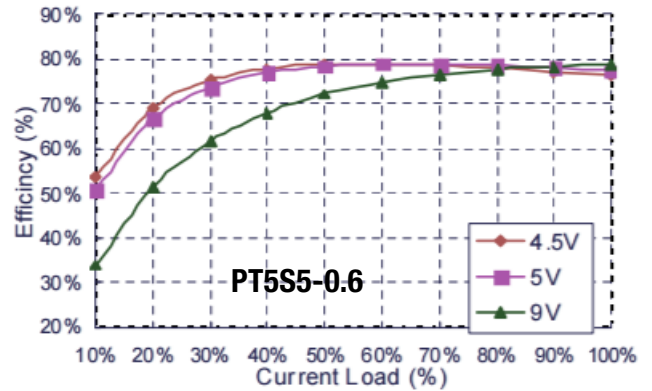
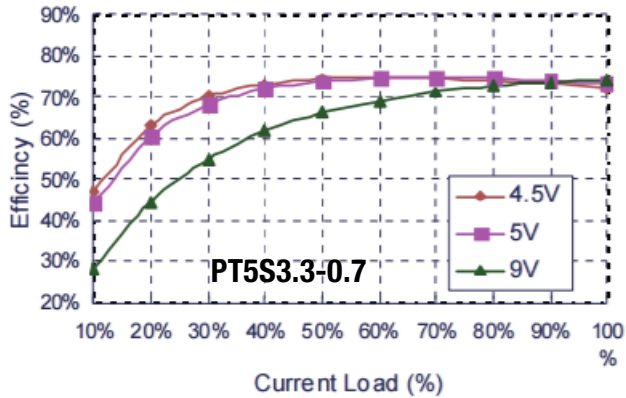

Efficiency vs. Load Curves

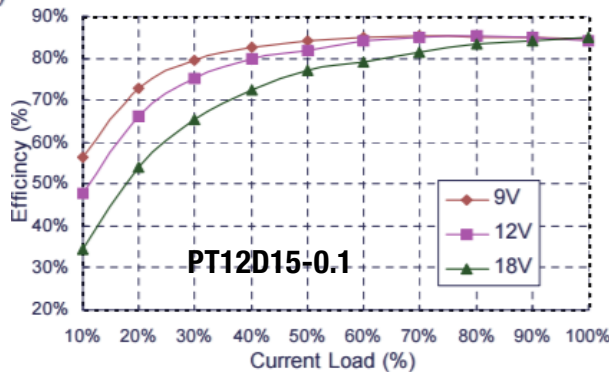
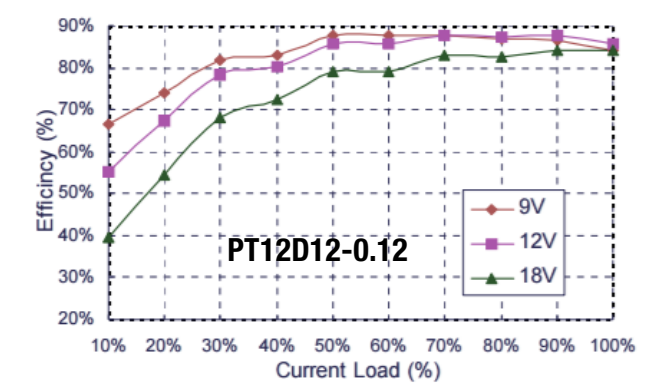
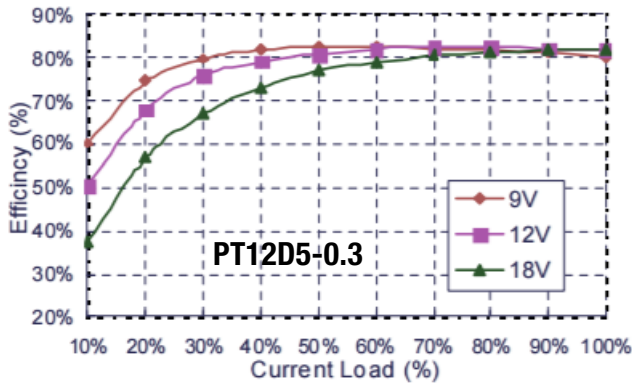
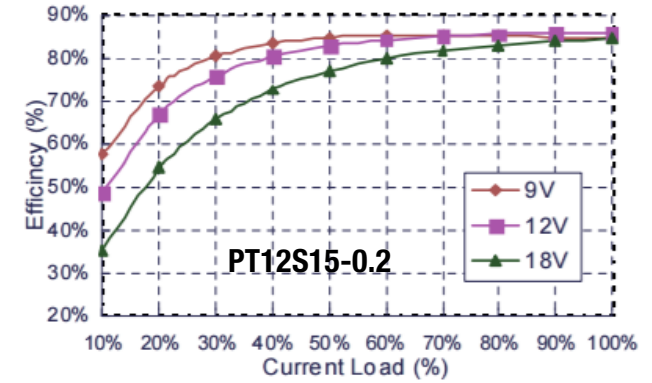
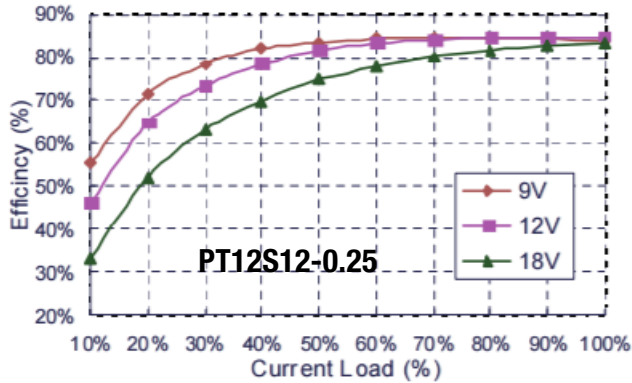
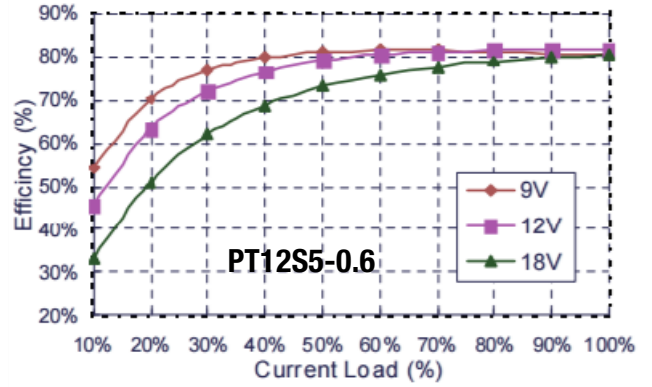
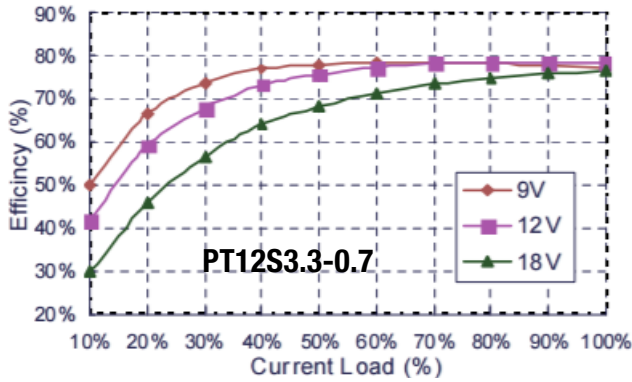

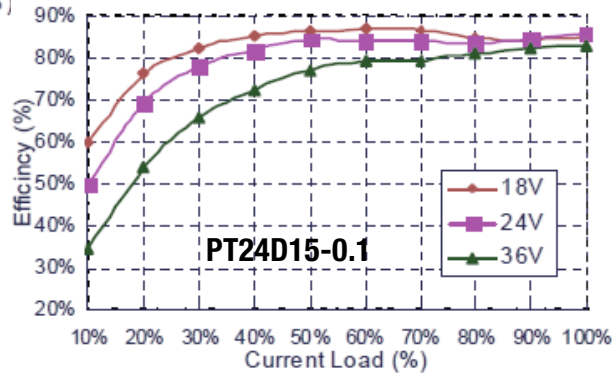
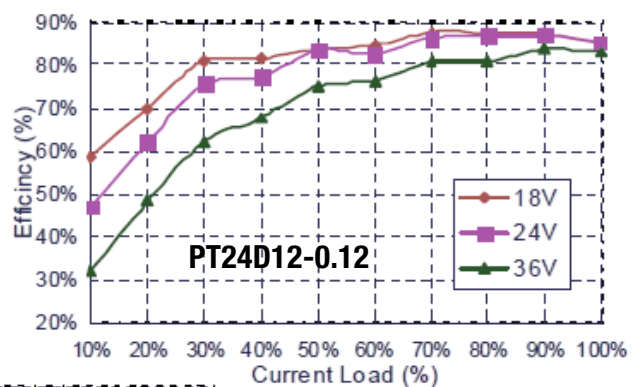
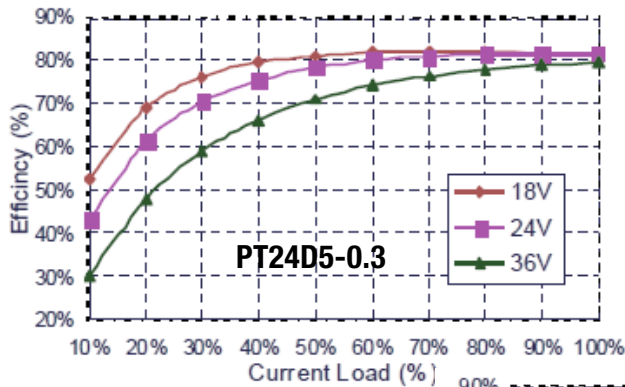
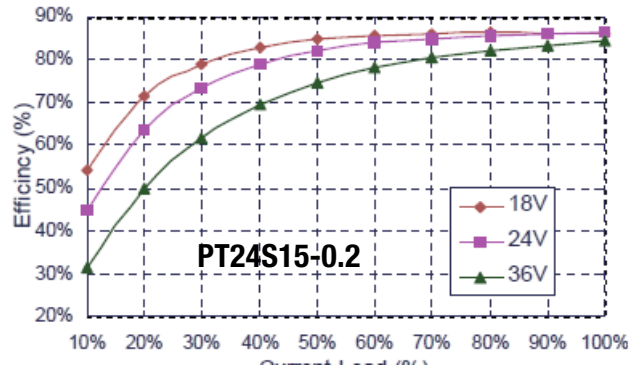
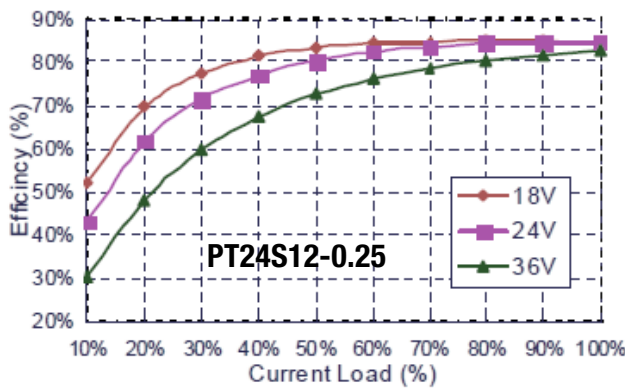
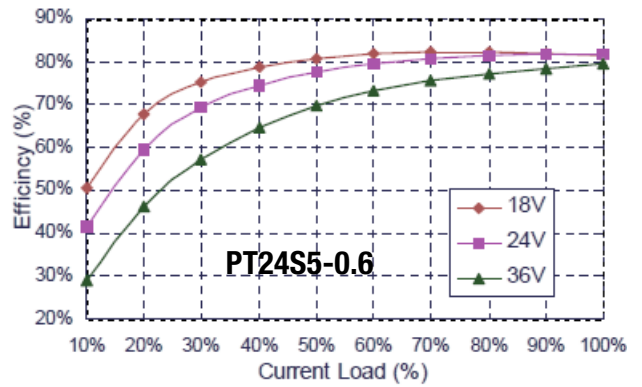
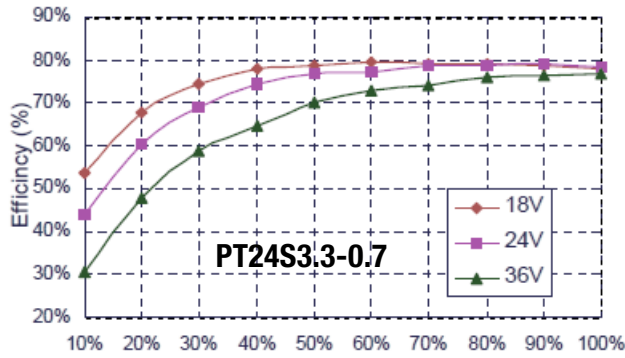

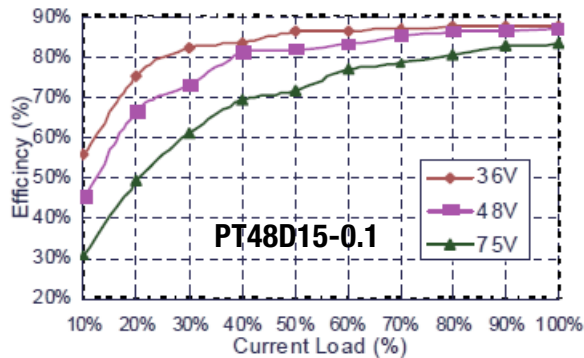
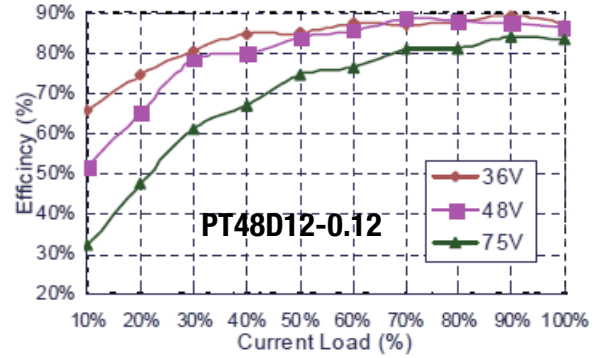
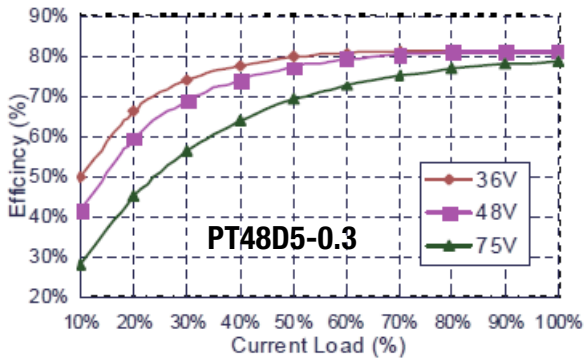
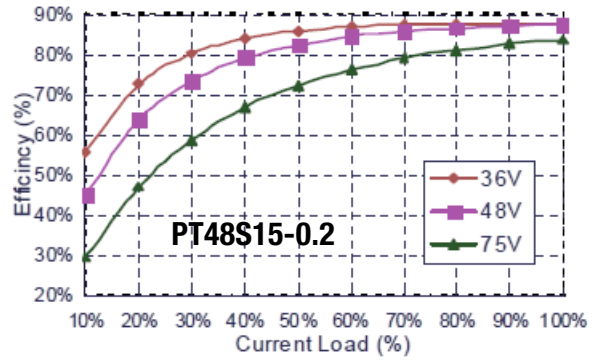
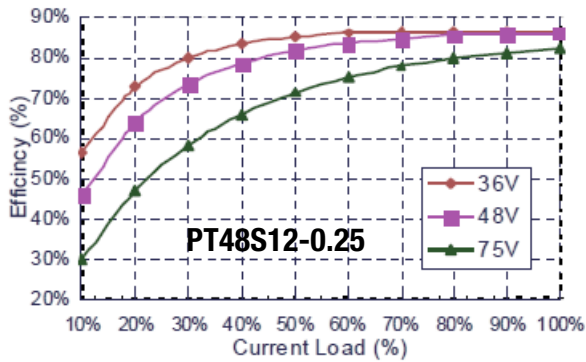
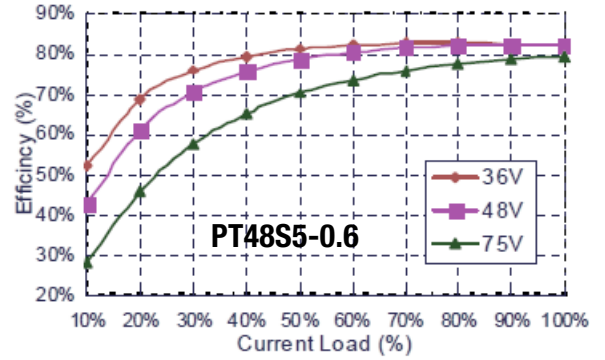
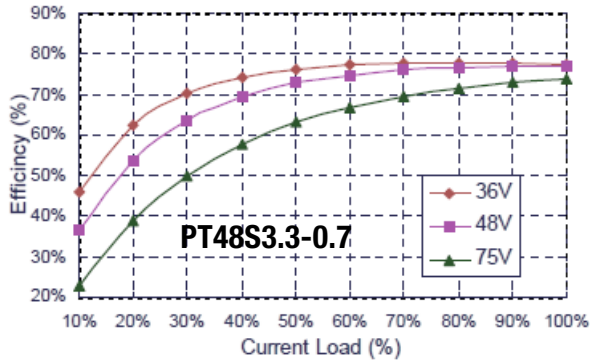

Input Capacitance at the Power Module

In order to avoid problems with loop stability, the converter must be connected to a low impedance AC source and a low inductance source. The input capacitors (C_{in}) should be placed close to the converter input pins to de-couple distribution inductance. The external input capacitors should have low ESR in order to quiet any ripple. Circuit as shown in the figure below represents typical measurement methods for reflected ripple current. The capacitor C1 and inductor L1 simulate the typical DC source impedance. The input reflected-ripple current is measured by a current probe oscilloscope with a simulated source inductance (L1).

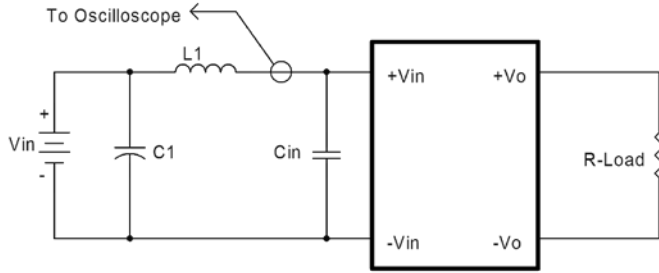

L1: 1uH
C1: None
Cin: 22uF ESR<0.7ohm @100KHz

Input Reflected-Ripple Test Setup

Test Set-Up

The basic test set-up to measure efficiency, load regulation, line regulation and other parameters is shown in the next figure. When testing the converter under any transient conditions, the user should ensure that the transient response of the source is sufficient to power the equipment under test. Below is the calculation of:

- 1- Efficiency
- 2- Load regulation
- 3- Line regulation

The value of efficiency is defined as:

$$\eta = \frac{V_O \times I_O}{V_{IN} \times I_{IN}} \times 100\%$$

Where

V_O is output voltage,
I_O is output current,
V_{IN} is input voltage,
I_{IN} is input current.

The value of load regulation is defined as:

$$Load.reg = \frac{V_{FL} - V_{NL}}{V_{NL}} \times 100\%$$

Where

V_{FL} is the output voltage at full load
V_{NL} is the output voltage at 10% load

The value of line regulation is defined as:

$$Line.reg = \frac{V_{HL} - V_{LL}}{V_{LL}} \times 100\%$$

Where

V_{HL} is the output voltage of maximum input voltage at full load.
V_{LL} is the output voltage of minimum input voltage at full load.

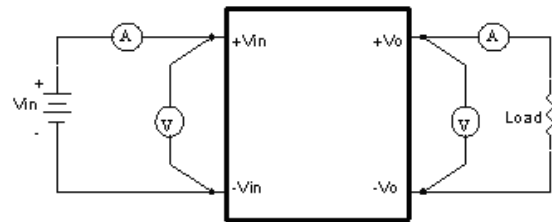

PT Series Test Setup

Output Ripple and Noise Measurement

The test set-up for noise and ripple measurements is shown in the figure below. A coaxial cable was used to prevent impedance mismatch reflections disturbing the noise readings at higher frequencies. Measurements are taken with the output appropriately loaded and all ripple/noise specifications are from D.C. to 20MHz Bandwidth.

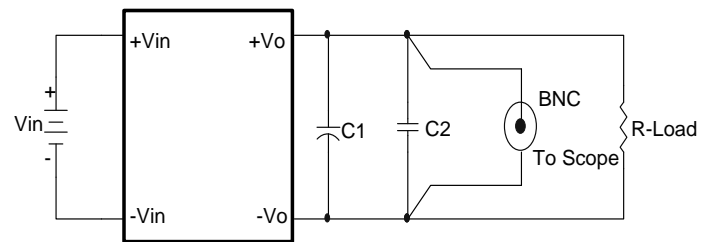

Note: C1: None
C2: None

Output Voltage Ripple and Noise Measurement Set-Up

Output Capacitance

The PT series converters provide unconditional stability with or without external capacitors. For good transient response, low ESR output capacitors should be located closer to the point of load.

SAFETY and EMC

Input Fusing and Safety Considerations

The PT series of converters do not have an internal fuse. However, to achieve maximum safety and system protection, always use an input line fuse. We recommended a time delay fuse 2A for 24Vin, 1A for 12Vin, and 500mA for 24Vin and 48Vin models. The circuit in the figure below is recommended and it uses by a Transient Voltage Suppressor diode across the input terminal to protect the unit against surge or spike voltage and input reverse voltage.

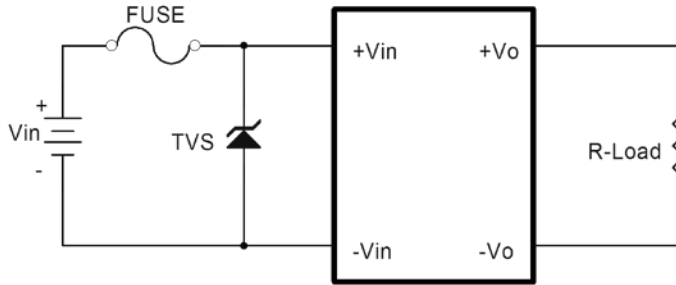

Input Protection

EMC Considerations

EMI Test standard: EN55022 Class A and Class B Conducted Emission

Test Condition: Input Voltage: Nominal, Output Load: Full Load

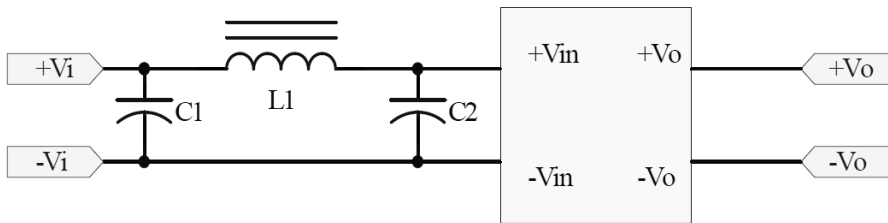

Connection circuit for conducted EMI testing

EN55022 class A			EN55022 class B			EN55022 class A			EN55022 class B		
Model No.	C1	L1	Model No.	C1	L1	Model No.	C1	L1	Model No.	C1	L1
PT5S3.3-0.7	10µF/16V 1206	2.2µH	PT5S3.3-0.7	10µF/25V 1210	10µH	PT24S3.3-0.7	4.7µF/50V 1812	12µH	PT24S3.3-0.7	6.8µF/50V 1812	33µF
PT5S5-0.6	10µF/16V 1206	2.2µH	PT5S5-0.6	10µF/25V 1210	10µH	PT24S5-0.6	4.7µF/50V 1812	12µH	PT24S5-0.6	6.8µF/50V 1812	33µF
PT512-0.25	10µF/16V 1206	2.2µH	PT512-0.25	10µF/25V 1210	10µH	PT2412-0.25	4.7µF/50V 1812	12µH	PT2412-0.83	6.8µF/50V 1812	33µF
PT5S15-0.2	10µF/16V 1206	2.2µH	PT5S15-0.2	10µF/25V 1210	10µH	PT24S15-0.2	4.7µF/50V 1812	12µH	PT24S15-0.2	6.8µF/50V 1812	33µF
PT5D5-0.3	10µF/16V 1206	2.2µH	PT5D5-0.3	10µF/25V 1210	10µH	PT24D5-0.3	4.7µF/50V 1812	12µH	PT24D5-0.3	6.8µF/50V 1812	33µF
PT5D12-0.12	10µF/16V 1206	2.2µH	PT5D12-0.12	10µF/25V 1210	10µH	PT24D12-0.12	4.7µF/50V 1812	12µH	PT24D12-0.12	6.8µF/50V 1812	33µF
PT5D15-0.1	10µF/16V 1206	2.2µH	PT5D15-0.1	10µF/25V 1210	10µH	PT24D15-0.1	4.7µF/50V 1812	12µH	PT24D15-0.1	6.8µF/50V 1812	33µF
PT12S3.3-0.7	2.2µF/25V 1206	12µH	PT12S3.3-0.7	2.2µF/25V 1210	33µH	PT48S3.3-0.7	1µF/100V 1812	68µF	PT48S3.3-0.7	2.2µF/100V 1812	150µF
PT12S5-0.6	2.2µF/25V 1206	12µH	PT12S5-0.6	2.2µF/25V 1210	33µH	PT48S5-0.6	1µF/100V 1812	68µF	PT48S5-0.6	2.2µF/100V 1812	150µF
PT1212-0.25	2.2µF/25V 1206	12µH	PT1212-0.25	2.2µF/25V 1210	33µH	PT4812-0.25	1µF/100V 1812	68µF	PT4812-0.83	2.2µF/100V 1812	150µF
PT12S15-0.2	2.2µF/25V 1206	12µH	PT12S15-0.2	2.2µF/25V 1210	33µH	PT48S15-0.2	1µF/100V 1812	68µF	PT48S15-0.2	2.2µF/100V 1812	150µF
PT12D5-0.3	2.2µF/25V 1206	12µH	PT12D5-0.3	2.2µF/25V 1210	33µH	PT48D5-0.3	1µF/100V 1812	68µF	PT48D5-0.3	2.2µF/100V 1812	150µF
PT12D12-0.12	2.2µF/25V 1206	12µH	PT12D12-0.12	2.2µF/25V 1210	33µH	PT48D12-0.12	1µF/100V 1812	68µF	PT48D12-0.12	2.2µF/100V 1812	150µF
PT12D15-0.1	2.2µF/25V 1206	12µH	PT12D15-0.1	2.2µF/25V 1210	33µH	PT48D15-0.1	1µF/100V 1812	68µF	PT48D15-0.1	2.2µF/100V 1812	150µF

Note: All of capacitors are ceramic capacitors

EMI and conducted noise meet EN55022 Class A

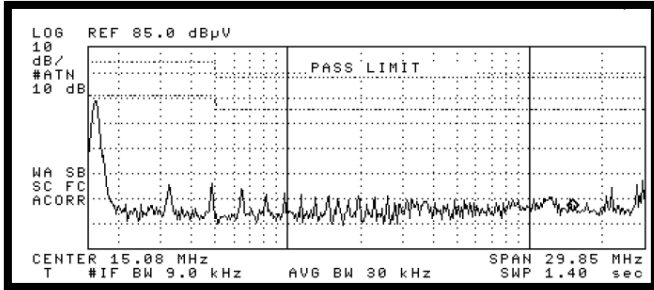

Class A Test conducted for PT5S5-0.6

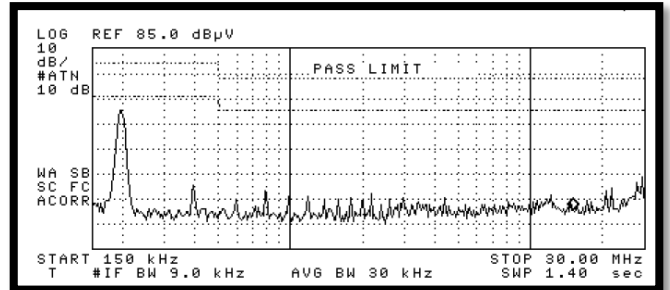

Class A Test conducted for PT12S12-2.5

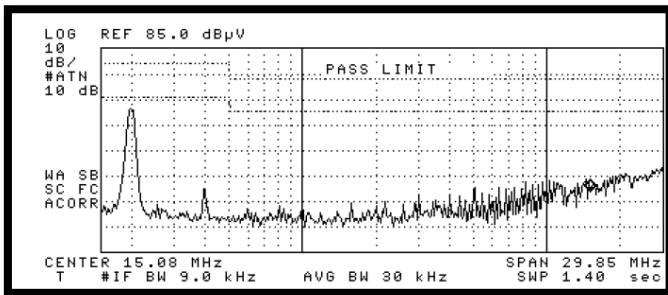

Class A Test conducted for PT24D5-0.3

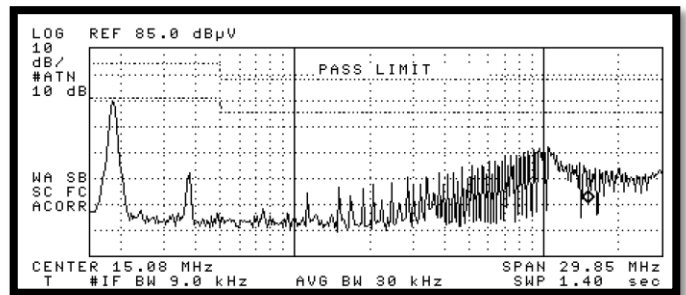

Class A Test conducted for PT48D12-0.12

EMI and conducted noise meet EN55022 Class B

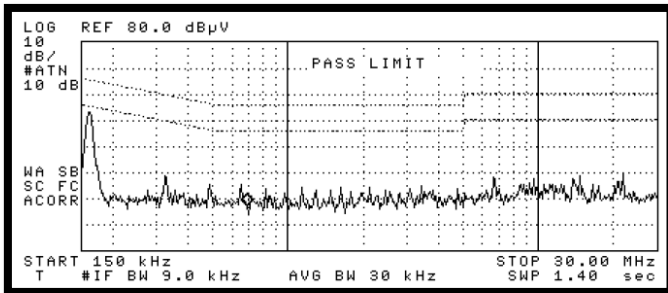

Class B Test conducted for PT5S5-0.6

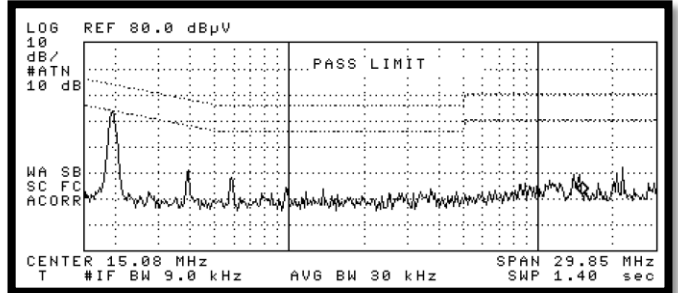

Class B Test conducted for PT12D5-0.3

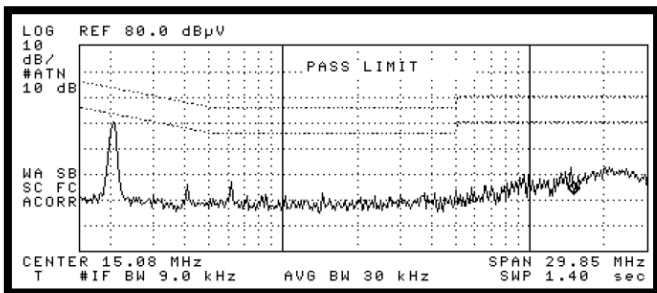

Class B Test conducted for PT24S12-0.12

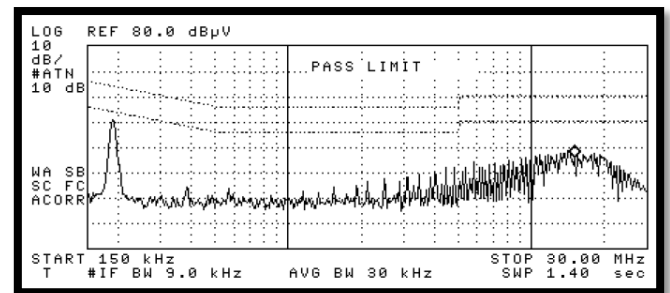

Class B Test conducted for PT48D15-0.1

MECHANICAL SPECIFICATIONS

Note: All dimensions are in Inches (millimeters). Tolerance: x.xx ±0.02 in. (0.5mm), x.xxx ±0.010 in. (0.25 mm) unless otherwise noted

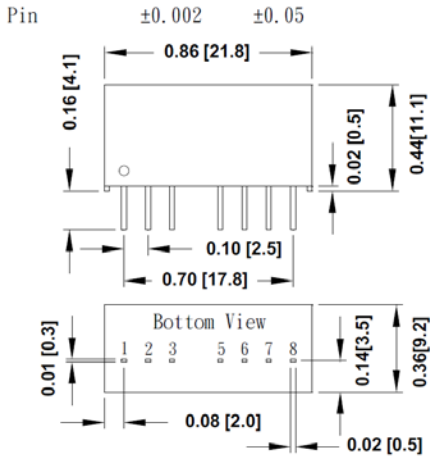

PIN CONNECTIONS

PIN CONNECTIONS		
PIN	SINGLE OUTPUT	DUAL OUTPUTS
1	- V Input	- V Input
2	+V Input	+V Input
3	On / Off	On / Off
5	No Connection	No Connection
6	+V Output	+V Output
7	-V Output	Common
8	No Connection	-V output

PART NUMBER ORDERING INFORMATION

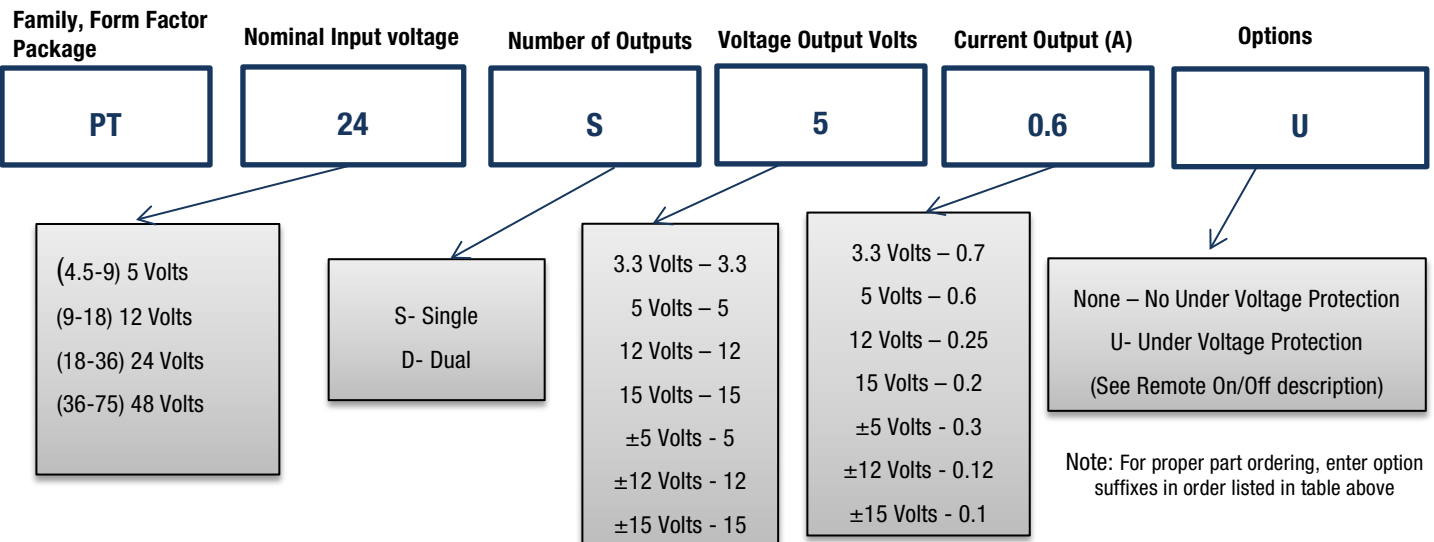

DATEL is a registered trademark of DATEL, Inc.
 11 Cabot Boulevard, Suite 200, Mansfield, MA 02048 USA
 ITR and ISO 9001/14001 REGISTERED

DATEL, Inc. makes no representation that the use of its products in the circuits described herein, or the use of other technical information contained herein, will not infringe upon existing or future patent rights. The descriptions contained herein do not imply the granting of licenses to make, use, or sell equipment constructed in accordance therewith. Specifications are subject to change without notice.

DATEL, Inc. 11 Cabot Boulevard, Suite 200, Mansfield, MA 02048 USA • Tel: (508) 964-5131 • www.datel.com • e-mail: help@datel.com