



## PRODUCT OVERVIEW

This QB series offers up to 150 watts of output power housed in an industry standard quarter-brick package with high power density. This QB series features wide input voltage ranges 9 to 36 or 18 to 75 VDC, high efficiency and isolation of 2250VDC and provide a precise regulated voltage output.

This QB models operate over the case temperature range of  $-40^{\circ}\text{C}$  to  $+105^{\circ}\text{C}$ . The modules offer Input under voltage lock out (UVLO), and are fully protected against output overvoltage and over temperature conditions. All models have internal over current and continuous short circuit protection. The output voltage can be trimmed to the required voltage and the product includes remote on/off function.

This QB series provides efficiency up to 92%, meet industrial standard and is the best choice for military, industrial, distributed power architectures, telecommunications, and mobile applications.

Please contact DATEL if your application requires different output voltage or any other special feature.

## FEATURES

- Isolated Output up to 150 Watts
- Wide input range (9 to 36 or 18 to 75 VDC)
- Regulated Outputs
- Efficiency up to 88%
- Remote On/Off
- Remote Sense
- Continuous Short Circuit Protection
- $-40^{\circ}\text{C}$  to  $+100^{\circ}\text{C}$
- Voltage/Current/Over-temperature Protection
- Quarter Brick Dimension
- Meet Industrial Standard
- CE Mark designed to meet 2014/30/EU
- Safety designed to meet UL60950-1, N60950-1 and IEC60950-1

## APPLICATIONS:

- Military Systems
- Distributed Power Systems
- mobile equipment
- Telecommunications

## AVAILABLE OPTIONS

- Customizable Input/ Output voltages
- Heatsink, customizable packaging
- UL/CSA60950-1
- CE Mark 2004/108/EC
- 100 Watt family is available in (4:1) Vin
- Lower power / optimized cost version available
- (2:1) Vin higher power version available

MODEL NUMBER	INPUT VOLTAGE	OUTPUT VOLTAGE	OUTPUT CURRENT MAX	EFFICIENCY %	LOAD REGULATION	OPTIONS
QB22S5-30	9-36 VDC	5.0 VDC	30 A	92	$\pm 0.2\%$	N, H1, H2
QB22S12-12.5	9-36 VDC	12 VDC	12.5 A	92	$\pm 0.2\%$	N, H1, H2
QB22S24-6.3	9-36 VDC	24 VDC	6.3 A	89	$\pm 0.2\%$	N, H1, H2
QB22S28-5.4	9-36 VDC	28 VDC	5.4 A	90	$\pm 0.2\%$	N, H1, H2
QB22S48-3.2	9-36 VDC	48 VDC	3.2 A	90	$\pm 0.2\%$	N, H1, H2
QB45S5-30	18-75 VDC	5.0 VDC	30 A	92	$\pm 0.2\%$	N, H1, H2
QB45S12-12.5	18-75 VDC	12 VDC	12.5 A	91	$\pm 0.2\%$	N, H1, H2
QB45S24-6.3	18-75 VDC	24 VDC	6.3 A	90	$\pm 0.2\%$	N, H1, H2
QB45S28-5.4	18-75 VDC	28 VDC	5.4 A	90	$\pm 0.2\%$	N, H1, H2
QB45S48-3.2	18-75 VDC	48 VDC	3.2 A	91	$\pm 0.2\%$	N, H1, H2

## BLOCK DIAGRAM

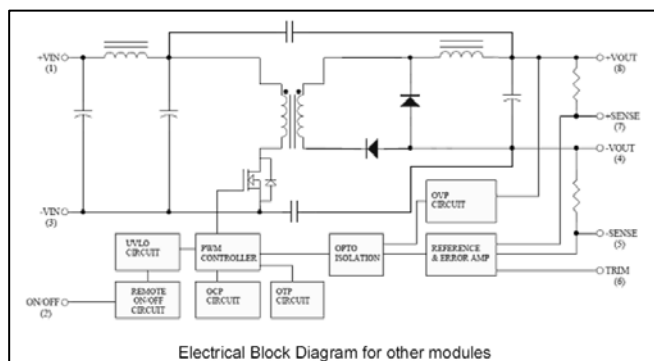
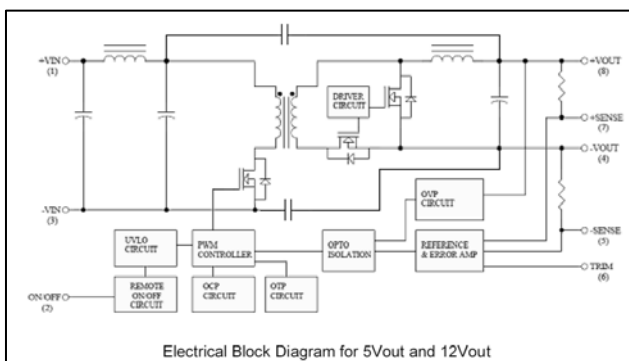

### ABSOLUTE MAXIMUM RATINGS

PARAMETER	CONDITIONS	Model	Min.	Typical	Max.	Units
Input Voltage						
Continuous	DC	24 Vin	-0.3		36	Volts
		48 Vin	-0.3		75	
Transient	100 ms, DC	24 Vin			50	Volts
		48 Vin			100	
Operating Case Temperature		All	-40		+105	°C
Storage Temperature		All	-55		+125	°C
Isolation Voltage	1 minute; input/output, input/case, output/case	All	2250			Volts

Stresses above the absolute maximum ratings can cause permanent damage to the device.

### FUNCTIONAL SPECIFICATIONS

The following specifications apply over the operating temperature range, under the following conditions TA = +25°C unless otherwise specified

#### INPUT CHARACTERISTICS

PARAMETER	CONDITIONS	Model	Min.	Typical	Max.	Units
Operating Input Voltage	DC	24 Vin	9	24	36	Volts
		48 Vin	18	48	75	
Input Under-voltage Lockout						
Turn-On Voltage Threshold	DC Vin (on)	24 Vin	8.0	8.5	8.8	Volts
		48 Vin	16.5	17.0	17.5	
Turn-Off Voltage Threshold	DC Vin (off)	24 Vin	7.7	8.0	8.3	Volts
		48 Vin	15.5	16.0	16.5	
Lockout Hysteresis Voltage		24 Vin		0.6		Volts
		48 Vin		0.9		
Maximum Input Current	100% Load, Vin= 9V 100% Load, Vin= 18V	24 Vin		20		A
		48 Vin		10		
No-Load Input Current	Vin=Nominal	QB22S5-30		10		mA
		QB22S12-12.5		10		
		QB22S24-6.3		10		
		QB22S28-5.4		10		
		QB22S48-3.2		10		
		QB45S5-30		8		
		QB45S12-12.5		8		
		QB45S24-6.3		8		
		QB45S28-5.4		8		
		QB45S48-3.2		8		
Inrush Current (I <sup>2</sup> t)		24 Vin			0.1	A <sup>2</sup> s
		48 Vin			0.1	
Input Reflected Ripple Current	P-P thru 12µH inductor, 5Hz to 20MHz	24 Vin		30		mA
		48 Vin		30		

**OUTPUT CHARACTERISTICS**

PARAMETER	CONDITIONS	Device	Min.	Typical	Max.	Units
Output Voltage Set Point	$V_{in}$ =Nominal $V_{in}$ , $I_o = I_{o\_max}$ , $T_c=25^\circ\text{C}$ DC	$V_o=5.0\text{ V}$	4.95	5	5.05	Volts
		$V_o=12\text{ V}$	11.88	12	12.2	
		$V_o=24\text{ V}$	23.76	24	24.24	
		$V_o=28\text{ V}$	27.72	28	28.28	
		$V_o=48\text{ V}$	47.52	48	48.48	
Output Voltage Regulation						
Load Regulation	$I_o=I_{o\_min}$ to $I_{o\_max}$	All			$\pm 0.2$	%
Line Regulation	$V_{in}$ =low line to high line	All			$\pm 0.2$	%
Temperature Coefficient	$T_c=-40^\circ\text{C}$ to $105^\circ\text{C}$	All			$\pm 0.02$	%/ $^\circ\text{C}$
Output Voltage Ripple and Noise (5Hz to 20MHz bandwidth)						
Peak-to-Peak	Full load, 10 $\mu\text{F}$ tantalum and 1.0 $\mu\text{F}$ ceramic capacitors	$V_o=5\text{ V}$			100	mV
		$V_o=12\text{ V}$			150	
		$V_o=24\text{ V}$			280	
		$V_o=28\text{ V}$			280	
		$V_o=48\text{ V}$			480	
RMS	Full load, 10 $\mu\text{F}$ solid tantalum and 1.0 $\mu\text{F}$ ceramic capacitors	$V_o=5\text{ V}$			40	mV
		$V_o=12\text{ V}$			60	
		$V_o=24\text{ V}$			100	
		$V_o=28\text{ V}$			100	
		$V_o=48\text{ V}$			200	
Operating Output Current Range		$V_o=5\text{ V}$	0		30	A
		$V_o=12\text{ V}$	0		12.5	
		$V_o=24\text{ V}$	0		6.3	
		$V_o=28\text{ V}$	0		5.4	
		$V_o=48\text{ V}$	0		3.2	
Output Voltage Trim Range		All	-10		10	%
Over Voltage Shutdown	Case	All		110		$^\circ\text{C}$
Over Voltage restart Hysteresis		All		10		$^\circ\text{C}$
Output Capacitance (External)		QB22S5-30 QB22S12-12.5 QB22S24-6.3 QB22S28-5.4 QB22S48-3.2 QB45S5-30 QB45S12-12.5 QB45S24-6.3 QB45S28-5.4 QB45S48-3.2		30,000 12,500 6,300 5,400 1,000 30,000 12,500 6,300 5,400 1,000		$\mu\text{F}$
Output Overvoltage Protection	Hiccup mode Limited Voltage	115	125	140		%
Output DC Current Limit inception	$V_o = 90\%$ Nominal Output Voltage Hiccup mode Auto Recovery	110	125	160		%

## DYNAMIC CHARACTERISTICS

PARAMETER	CONDITIONS	Model	Min.	Typical	Max.	Units
Output Voltage Current Transient						
Peak Deviation	75% to 100% of $I_{o\_max}$ step load change. $di/dt=0.1A/us$ (within 1% $V_{out}$ nominal)	$V_o=5V$			5	% $V_o$
		$V_o=12V$			5	
		$V_o=24V$			5	
		$V_o=28V$			5	
		$V_o=48V$			5	
Settling Time (< 1% $V_{out}$ nominal)		All			250	$\mu s$
Turn-On Delay and Rise Time						
Turn-On Delay Time	From On/Off Control $V_{on/off}$ to 10% $V_{o\_set}$	All		30		ms
Turn-On Delay Time	From Input, $V_{in\_min}$ to 10% $V_{o\_set}$	All		30		ms
Output Voltage Rise Time	10% $V_{o\_set}$ to 90% $V_{o\_set}$	All		30		ms

## EFFICIENCY

PARAMETER	CONDITIONS	Device	Min.	Typical	Max.	Units
Full Load	$V_{in}=\text{Nominal } V_{in}$ , $T_A=25^\circ C$	QB22S5-30		91		%
		QB22S12-12.5		91		
		QB22S24-6.3		89.5		
		QB22S28-5.4		90		
		QB22S48-3.2		90.5		
		QB45S5-30		92		
		QB45S12-12.5		92		
		QB45S24-6.3		91		
		QB45S28-5.4		91.5		
Full Load	$V_{in}=\text{Low line}$ , $V_{in}=12V$ for QB22 and $V_{in}=24V$ for QB45 at $T_A=25^\circ C$	QB22S5-30		91		%
		QB22S12-12.5		91		
		QB22S24-6.3		89.5		
		QB22S28-5.4		90		
		QB22S48-3.2		90.5		
		QB45S5-30		92		
		QB45S12-12.5		92		
		QB45S24-6.3		91		
		QB45S28-5.4		91.5		
QB45S48-3.2		92				

## ISOLATION CHARACTERISTICS

PARAMETER	CONDITIONS	Model	Min.	Typical	Max.	Units
Isolation Voltage	1 minute; input/output, input/case, output/case	All			2250	Volts
Isolation Resistance	input/output	All	10			$M\Omega$
Isolation Capacitance	Input/Output	All		1500		pF

### FEATURE CHARACTERISTICS

PARAMETER	CONDITIONS	Model	Min.	Typical	Max.	Units
Switching Frequency		QB45S12-12.5 Others	260 270	285 300	320 330	KHz
On/Off Control, Positive Remote On/Off logic						
Logic Low (Module Off)	$V_{on/off}$ at $I_{on/off}=1.0mA$	All	0		1.2	V
Logic Low (Module On)	$V_{on/off}$ at $I_{on/off}=0.0uA$	All	3.5 or Open Circuit		75	V
On/Off Control, Negative Remote On/Off logic						
Logic High (Module Off)	$V_{on/off}$ at $I_{on/off}=0.0uA$	All	3.5 or Open Circuit		75	V
Logic Low (Module On)	$V_{on/off}$ at $I_{on/off}=1.0mA$	All	0		1.2	V
On/Off Current Sink (for both remote on/off logic)	$I_{on/off}$ at $V_{on/off}=0.0V$	All		0.3	1	mA
Leakage Current (for both remote on/off logic)	Logic High, $V_{on/off}=15V$	All			30	$\mu A$
Off Converter Input Current	Shutdown input idle current	All		5	10	mA
Over Temperature Shutdown	Aluminum baseplate temperature			110		$^{\circ}C$
Over Temperature Recovery				100		$^{\circ}C$
MTBF	$I_o=100\%$ of $I_o max$ ; $T_a=25^{\circ}C$ per MIL-HDBK-217F	$V_o=5V$ $V_o=12V$ $V_o=24V$ $V_o=28V$ $V_o=48V$		309 331 563 560 667		Khours
Weight		All		68		grams

Please note that Case Material is Plastic (DAP), Baseplate Material is Aluminum, Potting Material is UL 94V-0, Pin Base Material is Copper and PIN Plating is Nickel with Matte Tin.

This QB series is designed to meet

- 1- This QB series meet Shock/Vibration MIL-STD-810F / EN61373
- 2- Humidity 95% RH max. Non Condensing
- 3- Altitude 3000m Operating Altitude, 12000m Transport Altitude
- 4- Thermal Shock MIL-STD-810F
- 5- EMI meets EN55022 class A with external input filter
- 6- ESD Meets EN61000-4-2 Air  $\pm 8$  Kv, Contact  $\pm 6$  kV Perf. Criteria A
- 7- Radiated immunity Meets EN61000-4-3 20 V/m Perf. Criteria A
- 8- Fast Transient Meets EN61000-4-4  $\pm 2$  kV , external input capacitor required
- 9- Surge Meets EN61000-4-5 EN55024:  $\pm 2$  kV , external input capacitor required,
- 10- Conducted immunity Meets EN61000-4-6 10Vrms Perf. Criteria A

**POWER DERATING**

The operating case temperature range of this QB series is -40°C to +105°C. When operating this QB series, proper derating or cooling is needed. The maximum case temperature under any operating condition should not exceed + 105°C.

Forced Convection Power De-rating without Heat Sink  
Example (without heatsink):

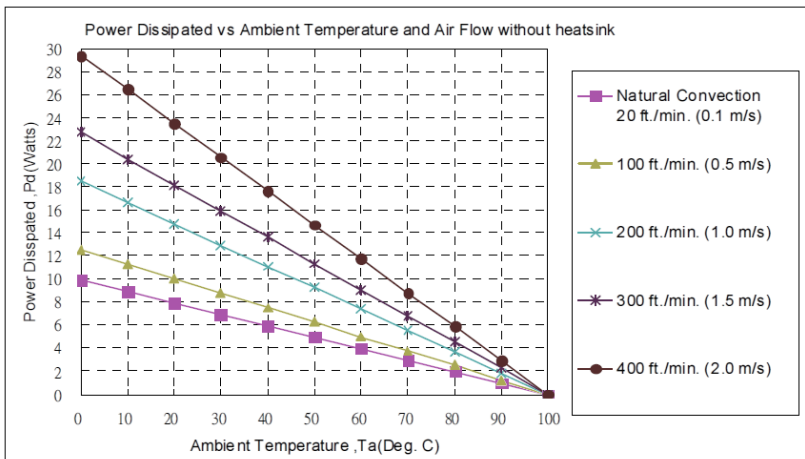

AIR FLOW RATE	TYPICAL R <sub>ca</sub>
Natural Convection	10.1 °C /W
20ft./min. (0.1m/s)	10.1 °C /W
100 ft./min. (0.5m/s)	8.0 °C /W
200 ft./min. (1.0m/s)	5.4 °C /W
300 ft./min. (1.5m/s)	4.4 °C /W
400 ft./min. (2.0m/s)	3.4 °C /W

What is the minimum airflow necessary for a QB48S12-12.5 operating at nominal line voltage, an output current of 12.5A, and a maximum ambient temperature of 40°C?

**Solution:**

Given:

$V_{in} = 48V_{dc}$ ,  $V_o = 12V_{dc}$ ,  $I_o = 12.5A$

**Determine Power dissipation (Pd):**

$P_d = P_i - P_o = P_o(1 - \eta) / \eta$

$P_d = 12V \times 12.5A \times (1 - 0.9) / 0.9 = 16.67 \text{ Watts}$

**Determine airflow:**

Given:  $P_d = 16.67W$  and  $T_a = 40^\circ C$

**Check Power Derating curve:**

Airflow  $\leq 400 \text{ ft./min.}$

**Verify:**

The maximum temperature rise:

$\Delta T = P_d \times R_{ca} = 16.67 \times 3.4 = 56.68^\circ C$

The maximum case temperature

$T_c = T_a + \Delta T = 96.68^\circ C < 105^\circ C$

**Where:**

R<sub>ca</sub> is thermal resistance from case to ambience.

T<sub>a</sub> is ambient temperature and the T<sub>c</sub> is case temperature

Example (with heatsink M-C421)

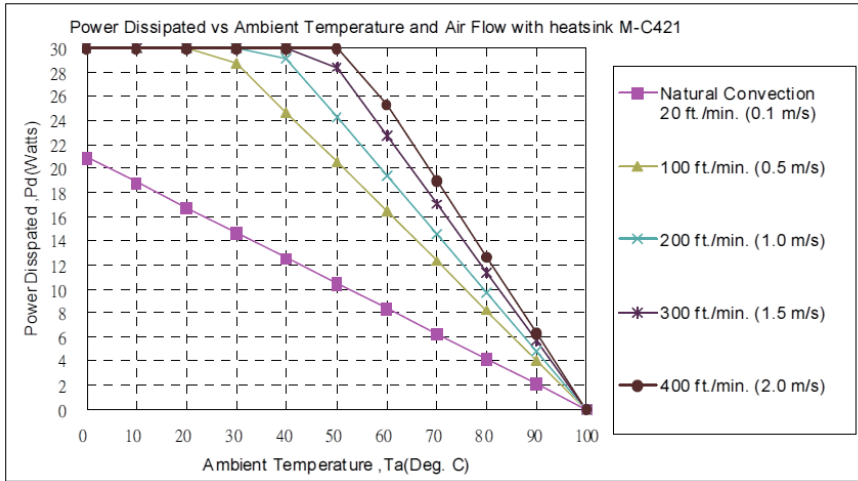

AIR FLOW RATE	TYPICAL R <sub>ca</sub>
Natural Convection 20ft./min. (0.1m/s)	4.78 °C/W
100 ft./min. (0.5m/s)	2.44 °C/W
200 ft./min. (1.0m/s)	2.06 °C/W
300 ft./min. (1.5m/s)	1.76 °C/W
400 ft./min. (2.0m/s)	1.58 °C/W

What is the minimum airflow necessary for a QB22S5-30 operating at nominal line voltage, an output current of 30A, and a maximum ambient temperature of 40°C?

**Solution:**

**Given:**

Given: Vin=24Vdc, Vo=5Vdc, Io=30A

**Determine Power dissipation (Pd):**

$$P_d = P_i - P_o = P_o(1-\eta)/\eta$$

$$P_d = 5.0 \times 30 \times (1-0.89)/0.89 = 18.54 \text{ Watts}$$

**Determine airflow:**

Given: Pd=18.54W and Ta=40°C

**Check Power de-rating curve:**

Airflow  $\leq$  100 ft./min.

**Verify:**

$$\text{The maximum temperature rise } \Delta T = P_d \times R_{ca} = 18.54 \times 2.44 = 45.24^\circ\text{C}$$

$$\text{The maximum case temperature } T_c = T_a + \Delta T = 85.24^\circ\text{C} < 100^\circ\text{C}$$

**Where:**

R<sub>ca</sub> is thermal resistance from case to ambient environment.

T<sub>a</sub> is ambient temperature and T<sub>c</sub> is case temperature.

**QUARTER BRICK HEAT SINKS:**

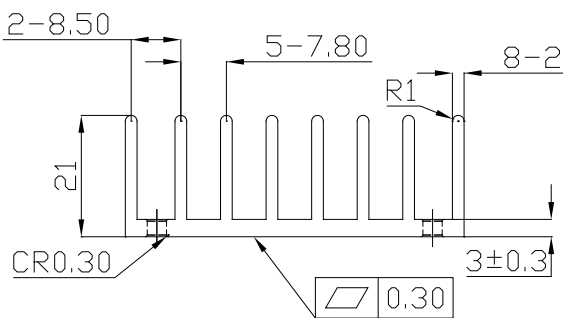
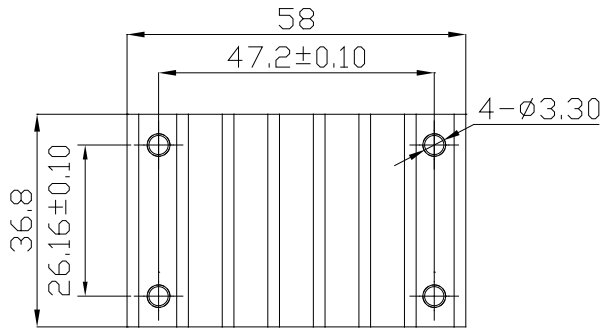

**M-C421 (G6620510201)**  
**Transverse Heat Sink**

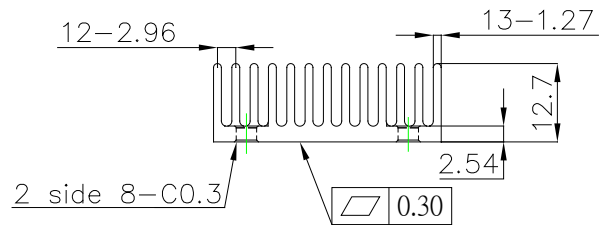
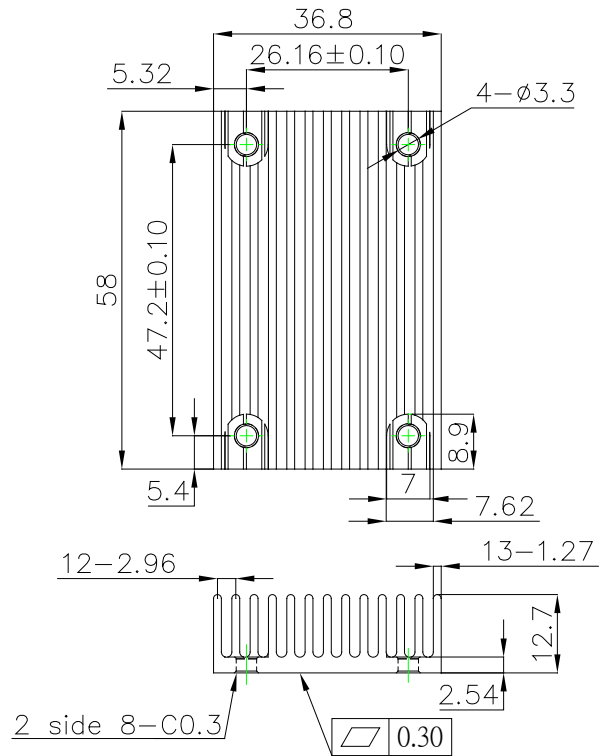

**M-C488 (G6620570202)**  
**Longitudinal Heat Sink**

All Dimensions in mm

Rca: 4.78°C/W (typ.), At natural convection  
2.44°C/W (typ.), At 100LFM  
2.06°C/W (typ.), At 200LFM  
1.76°C/W (typ.), At 300LFM  
1.58°C/W (typ.), At 400LFM

Rca: 5.61°C/W (typ.), At natural convection  
4.01°C/W (typ.), At 100LFM  
3.39°C/W (typ.), At 200LFM  
2.86°C/W (typ.), At 300LFM  
2.49°C/W (typ.), At 400LFM

THERMAL PAD: SZ 35.8\*56.9\*0.25 mm (G6135041041)  
SCREW: SMP+SW M3\*8L (G75A1300322)



**EFFICIENCY vs. LOAD**

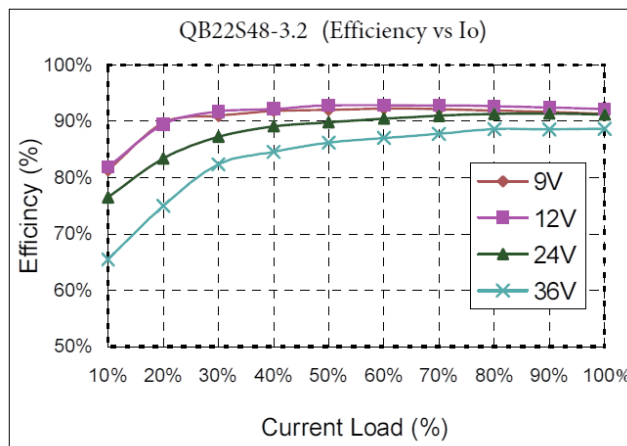
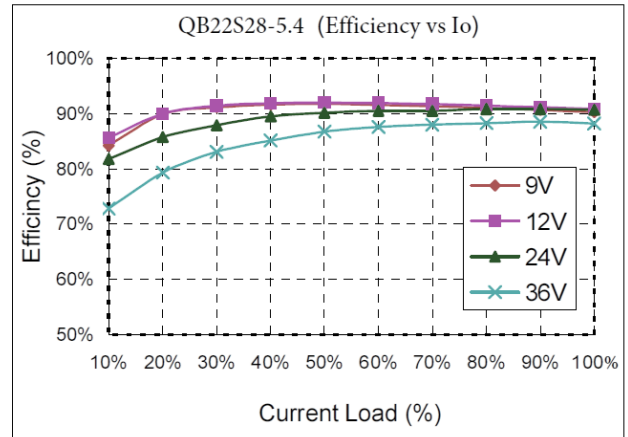
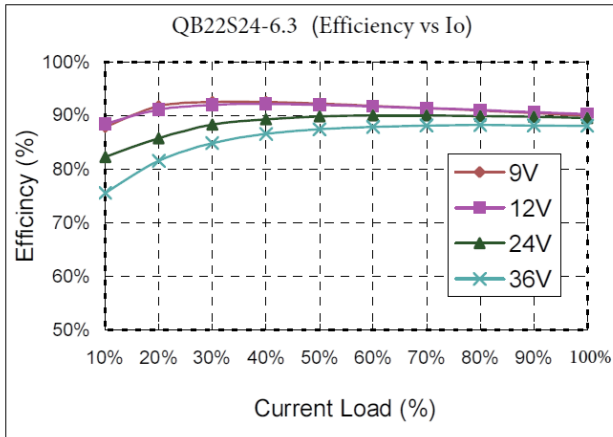
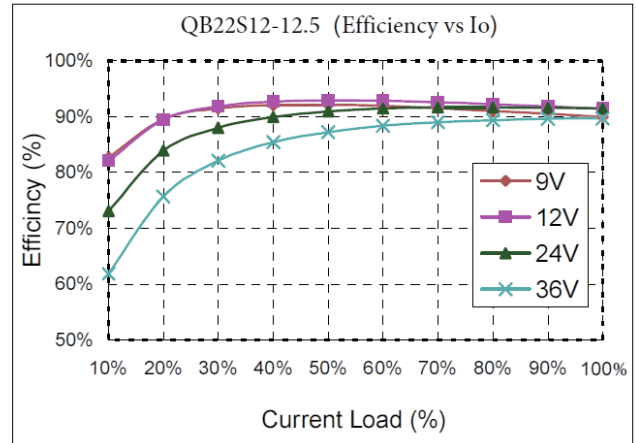
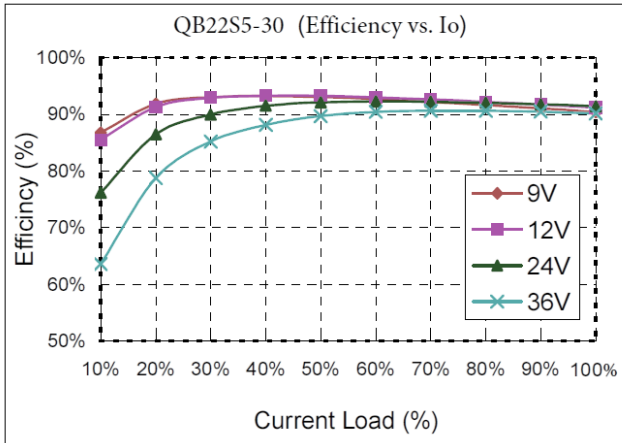

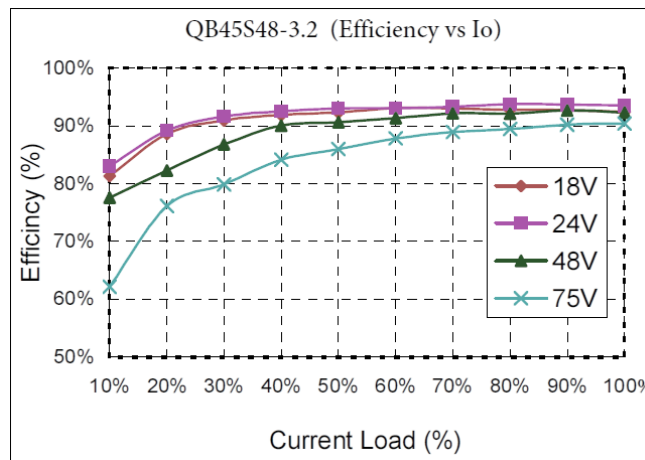
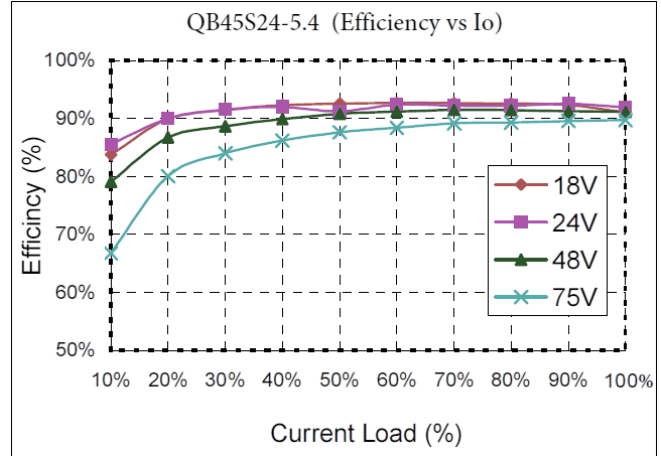
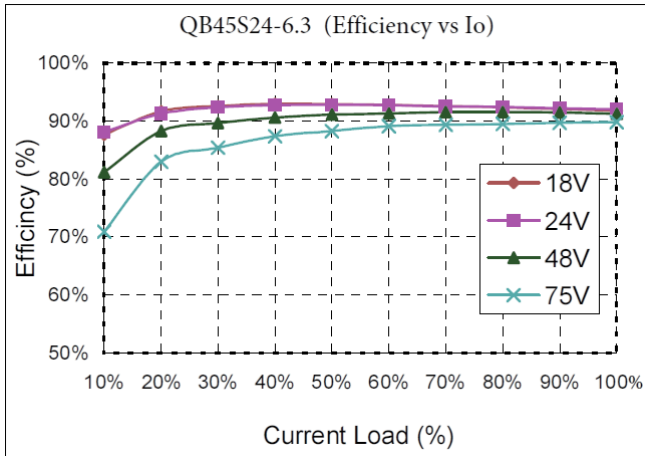
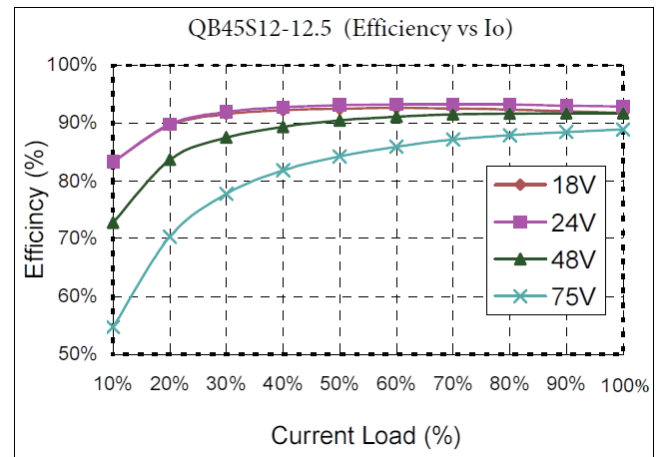
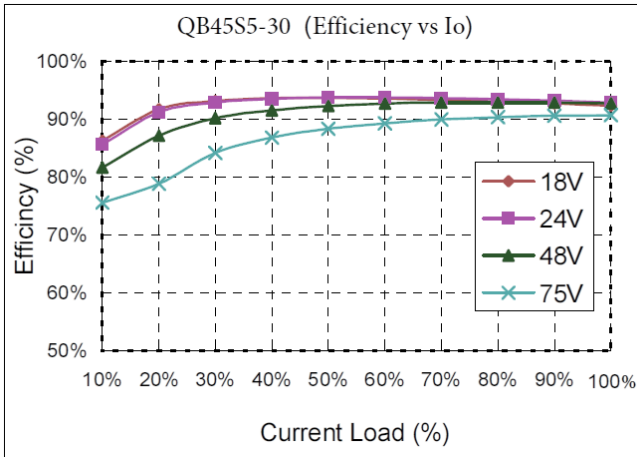

### Operating Temperature Range

This QB series of converters can be operated over a wide case temperature range of -40°C to +100°C. Consideration must be given to the derating curves when maximum power is drawn from the converter. The maximum power drawn from open half brick models is influenced by multiple factors, such as:

- Input voltage range
- Output load current
- Forced air or natural convection
- Heat sink

### Output Voltage Adjustment

The next page describes in detail how to trim the output voltage with respect to its set point. The output voltage on all models is adjustable within the range of -10% to +10%.

### Over Current Protection

All models have internal over current and continuous short circuit protection. Once the fault condition is removed, the unit will operate normally. The converter will go into hiccup mode protection once the point of current limit inception is reached.

### Output Overvoltage Protection

The output overvoltage protection consists of circuitry that internally limits the output voltage. If more accurate output over voltage protection is required then an external circuit can be used via the Remote On/Off pin. Please note that device inside the power supply may fail when voltage more than the rated output voltage is applied to output pin. This can happen when testing the over voltage protection of unit

### Remote On/Off

The QB series allows the user to switch the module on and off electronically with the remote on/off feature. All models are available in "positive logic" and "negative logic" (optional) versions. The converter turns on if the remote on/off pin is high (>3.5Vdc or open circuit). Setting the pin low (<1.2VDC) will turn the Converter off. The signal level of the remote on/off input is defined with respect to ground. If not using the remote on/off pin, leave the pin open (converter will be on). Models with part number suffix "N" are the "negative logic" remote on/off version. The unit turns off if the remote on/off pin is high (>3.5Vdc or open circuit). The converter turns on if the on/off pin input is low (<1.2VDC). The converter is off by default. If not using the remote on/off feature, leave the ON/OFF pin open for positive logic, and short the ON/OFF pin to VIN(-) for negative logic.

### UVLO (Under voltage Lock Out)

Input under voltage lockout is standard on the QB unit. The unit will shut down when the input voltage drops below a threshold, and the unit will operate when the input voltage goes above the upper threshold.

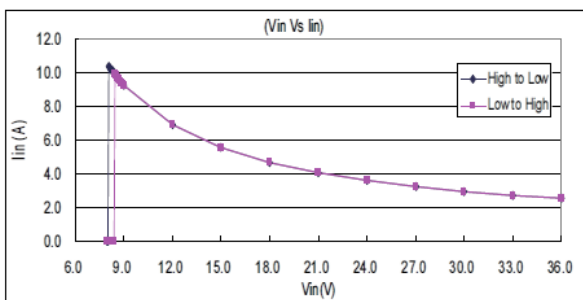

QB22SXX series I<sub>in</sub> vs V<sub>in</sub>

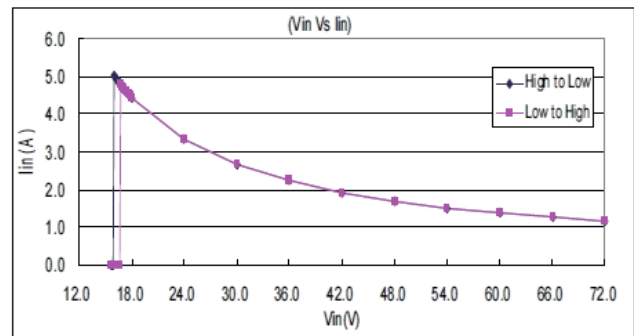

QB45SXX series I<sub>in</sub> vs V<sub>in</sub>

### Over Temperature Protection

These modules have an over temperature protection circuit to safeguard against thermal damage. Shutdown occurs with the maximum case reference temperature is exceeded. The module will restart when the case temperature falls below over temperature shutdown threshold. The case temperature is measured at the center part of the aluminum baseplate.

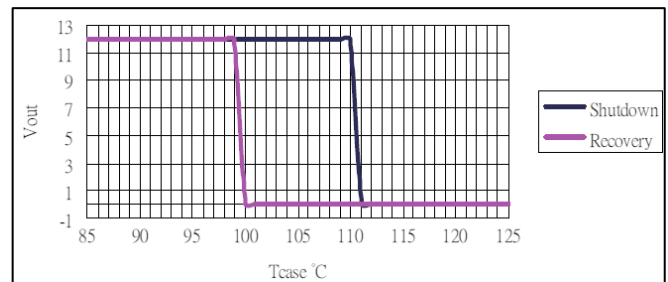

Shutdown and Recovery Graph

### PCB Foot print, Recommended Layout, and Soldering Information

The user of the converter must ensure that other components and metal in the vicinity of the converter meet the spacing requirements to which the system is approved. Low resistance and low inductance PCB layout traces should be used where possible. Careful consideration must also be given to proper low impedance tracks between power module, input and output grounds. The recommended footprints and soldering profiles are shown in the next two figures

#### Lead Free Wave Soldering Profile

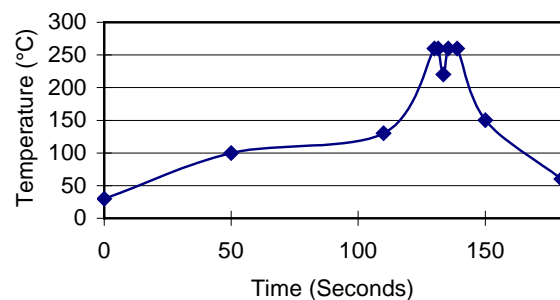

Note :

1. Soldering Materials: Sn/Cu/Ni
2. Ramp up rate during preheat: 1.4 °C/Sec (From + 50°C to +100°C)
3. Soaking temperature: 0.5 °C/Sec (From +100°C to + 130°C), 60 ± 20 seconds
4. Peak temperature: +260°C, above+ 250°C 3~6 Seconds

5. Ramp up rate during cooling: -10.0 °C/Sec (From+ 260°C to +150°C)

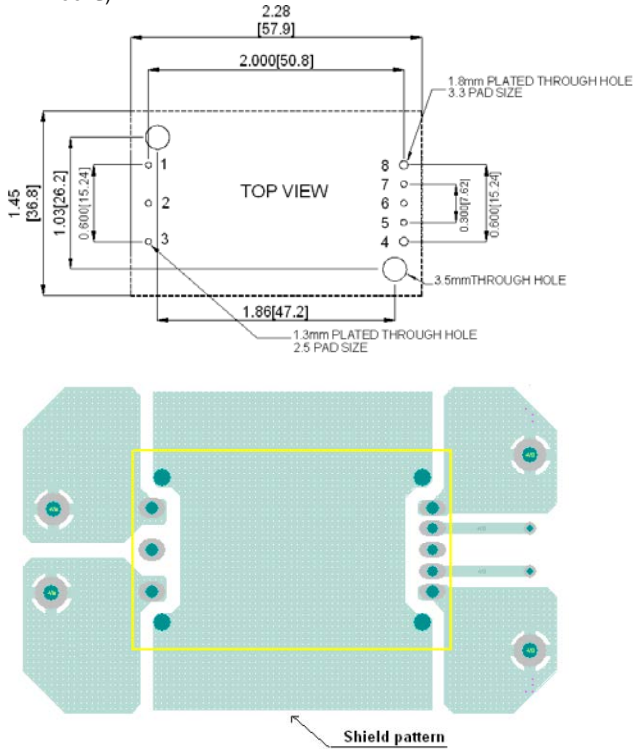

**Convection Requirements for Cooling**

To predict the approximate cooling needed for the Quarter brick module, refer to the power derating curves. These derating curves are approximations of the ambient temperatures and airflows required to keep the power module temperature below its maximum rating. Once the module is assembled in the actual system, the module’s temperature should be monitored to ensure it does not exceed +105°C as measured at the center of the top of the case (thus verifying proper cooling).

**Thermal Considerations**

The power module operates in a variety of thermal environments; however, sufficient cooling should be provided to help ensure reliable operation of the unit. Heat is removed by conduction, convection, and radiation to the surrounding environment. The power output of the module should not be allowed to exceed rated power ( $V_{o\_set} \times I_{o\_max}$ ).

**Connection for standard use**

The connection for standard use is shown below. An external input capacitor (C1) 220uF for all models is recommended to reduce input ripple voltage. External output capacitors (C2, C3) are recommended to reduce output ripple and noise, 10uF aluminum and 1uF ceramic capacitor for 48Vout, and 10uF tantalum and 1uF ceramic capacitor for other models.

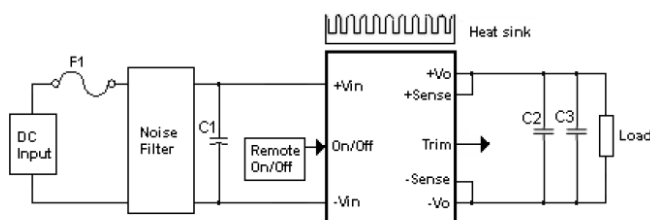

If the impedance of input line is high, C1 capacitance must be more than above. Use more than two recommended capacitor above in parallel when ambient temperature becomes lower than -20 °C.

**Input Capacitance at the Power Module**

The converters must be connected to low AC source impedance. To avoid problems with loop stability source inductance should be low. Also, the input capacitors (Cin) should be placed close to the converter input pins to decouple distribution inductance. However, the external input capacitors are chosen for suitable ripple handling capability. Low ESR capacitors are good choice. Circuit as shown as below represents typical measurement methods for reflected ripple current. C1 and L1 simulate a typical DC source impedance. The input reflected-ripple current is measured by current probe to oscilloscope with a simulated source Inductance (L1).

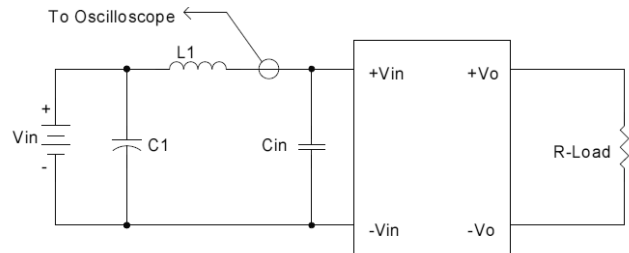

- L1: 12uH
- C1: 470uF ESR<0.1ohm @100KHz
- Cin: 470uF ESR<0.7ohm @100KHz

**TEST SET-UP**

The basic test set-up to measure parameters such as efficiency and load regulation is shown below. When testing the modules under any transient conditions please ensure that the transient response of the source is sufficient to power the equipment under test. We can calculate:

- Efficiency
- Load regulation
- Line regulation.

The value of efficiency is defined as:

$$\eta = \frac{V_o \times I_o}{V_{in} \times I_{in}} \times 100\%$$

Where:

$V_o$  is output voltage,  
 $I_o$  is output current,  
 $V_{in}$  is input voltage,  
 $I_{in}$  is input current.

The value of load regulation is defined as:

$$\text{Load.reg} = \frac{V_{FL} - V_{NL}}{V_{NL}} \times 100\%$$

Where:

$V_{FL}$  is the output voltage at full load  
 $V_{NL}$  is the output voltage at no load

The value of line regulation is defined as:

$$\text{Line.reg} = \frac{V_{HL} - V_{LL}}{V_{LL}} \times 100\%$$

Where:

$V_{HL}$  is the output voltage of maximum input voltage at full load.  
 $V_{LL}$  is the output voltage of minimum input voltage at full load.

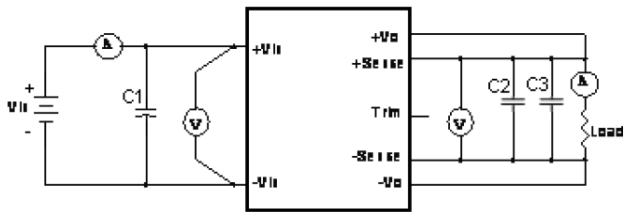

QB Series Test Setup

- C1: 220uF/100V ESR<0.035Ω
- C2: 1uF/ 1210 ceramic capacitor
- C3: 10uF aluminum capacitor for 48Vout. 10uF tantalum capacitor for others.

**Output Voltage Adjustment**

The Trim input permits the user to adjust the output voltage up or down 10%. This is accomplished by connecting an external resistor between the Trim pin and either the VO(+) pin or the VO(-) pin (COM pin). In order to trim the voltage up or down, one needs to connect the trim resistor either between the trim pin and -Sense for trim-up or between trim pin and +Sense for trim-down. The output voltage trim range is ±10%. This is shown:

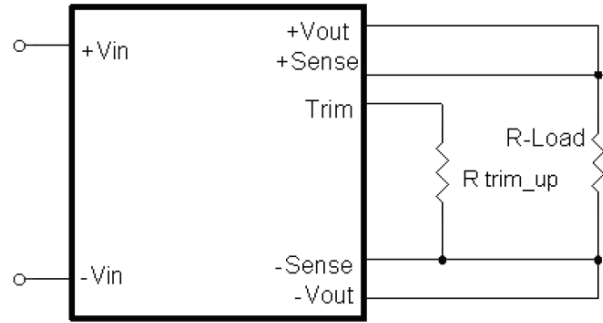

Trim-up Voltage Setup

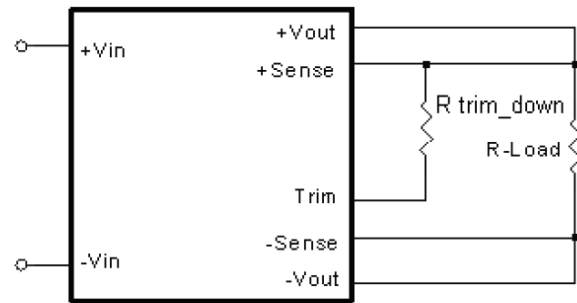

Trim-down Voltage Setup

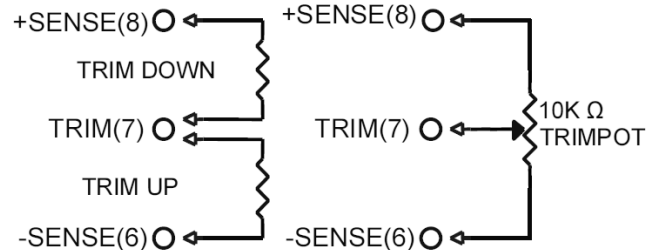

Vout (V)	R1 (Ω)	R2 (Ω)	R2 (Ω)	Vr (V)	Vf (V)
5 Volts	2320	3300	0	2.5	0
12 Volts	9100	51000	5100	2.5	0.46
24 Volts	20000	100000	7500	2.5	0.46
28 Volts	23700	150000	6200	2.6	0.64
48 Volts	3600	270000	5100	2.5	0.46

The value of Rtrim\_up defined as:

For Vo=5V Rtrim\_up decision:

$$R_{trim\_up} = \frac{R_1 V_r}{V_o - V_{o\_nom}} - R_2 \text{ (K}\Omega\text{)}$$

For others Rtrim\_up decision:

$$R_{trim\_up} = \left( \frac{R_1 (V_r - V_f (\frac{R_2}{R_2 + R_3}))}{V_o - V_{o\_nom}} \right) - \frac{R_2 R_3}{R_2 + R_3} \text{ (K}\Omega\text{)}$$

Where:

- Rtrim\_up is the external resistor in KΩ.
- Vo\_nom is the nominal output voltage.
- Vo is the desired output voltage.
- R1, R2, R3 and Vr are internal components.

For example, to trim-up the output voltage of 12V module (QB45S12-12.5) by 5% to 12.6V, R<sub>trim\_up</sub> is calculated as follows:

$$V_o - V_{o\_nom} = 12.6 - 12 = 0.6V$$

$$R1 = 9.1\text{ K}\Omega, R2 = 51\text{ K}\Omega, R3 = 5.1\text{K}\Omega,$$

$$V_r = 2.5\text{ V}, V_f = 0.46\text{ V}$$

$$R_{trim\_up} = \frac{18.944}{0.6} - 4.636 = 26.94\text{ (K}\Omega\text{)}$$

The value of R<sub>trim\_down</sub> defined as:

$$R_{trim\_down} = \frac{R1 \times (V_o - V_r)}{V_{o\_nom} - V_o} - R2\text{ (K}\Omega\text{)}$$

Where:

R<sub>trim\_down</sub> is the external resistor in KΩ.

V<sub>o\_nom</sub> is the nominal output voltage.

V<sub>o</sub> is the desired output voltage.

R<sub>1</sub>, R<sub>2</sub>, R<sub>3</sub> and V<sub>r</sub> are internal components.

For example: to trim-down the output voltage of the 12V module QB45S12-12.5 by 5% to 11.4V, R<sub>trim\_down</sub> is calculated as follows:

$$V_{o\_nom} - V_o = 12 - 11.4 = 0.6\text{ V}$$

$$R1 = 9.1\text{ K}\Omega, R2 = 51\text{ K}\Omega, V_r = 2.5\text{ V}$$

$$R_{trim\_down} = \frac{9.1 \times (11.4 - 2.5)}{0.6} - 51 = 83.98\text{ (K}\Omega\text{)}$$

The typical value of R<sub>trim\_up</sub> in K Ω

	5V	12V	24V	28V	48V
Trim up %	R <sub>trim_up</sub> (KΩ)				
1%	112.7	153.2	165.7	168.3	148.6
2%	54.70	74.30	79.36	81.16	71.81
3%	35.37	47.99	50.58	52.12	46.21
4%	25.70	34.83	36.19	37.60	33.40
5%	19.90	26.94	27.56	28.86	25.72
6%	16.03	21.68	21.80	23.08	20.60
7%	13.27	17.92	17.69	18.93	16.94
8%	11.20	15.10	14.61	15.82	14.20
9%	9.589	12.91	12.21	13.40	12.07
10%	8.300	11.15	10.29	11.47	10.36

The typical value of R<sub>trim\_down</sub> in KΩ:

	5V	12V	24V	28V	48V
Trim down %	R <sub>trim_down</sub> (KΩ)				
1%	110.4	660.3	1671	1984	3106
2%	52.38	300.1	775.8	905.5	1400
3%	33.05	180.0	477.2	545.8	831.5
4%	23.38	120.0	327.9	365.9	547.1
5%	17.58	83.99	238.3	258.0	376.5
6%	13.71	59.97	178.6	186.0	262.8
7%	10.95	42.82	136.0	134.6	181.5
8%	8.880	29.95	104.0	96.10	120.6
9%	7.269	19.95	79.07	66.12	73.17
10%	5.980	11.94	59.17	42.14	35.25

## Output Remote Sensing

This QB series converter has the capability to remotely sense both lines of its output. This feature moves the effective output voltage regulation point from the output of the unit to the point of connection of the remote sense pins. This feature automatically adjusts the real output voltage of the QB series in order to compensate for voltage drops in distribution and maintain a regulated voltage at the point of

load. The remote-sense voltage range is: [(+V<sub>out</sub>) - (-V<sub>out</sub>)] - [(+Sense) - (-Sense)] ≤ 10% of V<sub>o\_nominal</sub>

When remote sense is in use, the sense should be connected by twisted-pair wire or shield wire. If the sensing patterns short, heavy current flows and the pattern may be damaged. Output voltage might become unstable because of impedance of wiring and load condition when length of wire is exceeding 400mm. This is shown in the schematic below.

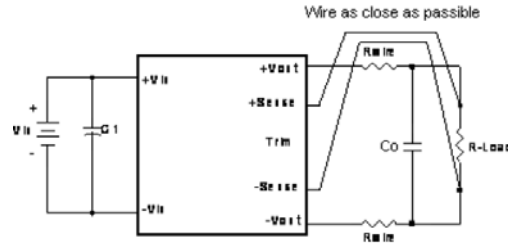

If the remote sense feature is not to be used, the sense pins should be connected locally. The +Sense pin should be connected to the +V<sub>out</sub> pin at the module and the -Sense pin should be connected to the -V<sub>out</sub> pin at the module. Wire between +Sense and +V<sub>out</sub> and between -Sense and -V<sub>out</sub> as short as possible. Loop wiring should be avoided. The converter might become unstable by noise coming from poor wiring. This is shown in the schematic below.

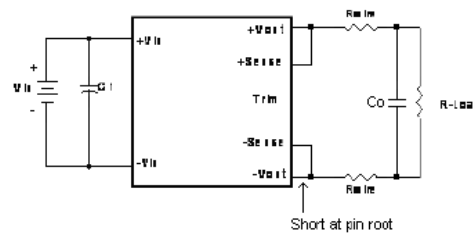

Note: Although the output voltage can be varied (increased or decreased) by both remote sense and trim, the maximum variation for the output voltage is the larger of the two values not the sum of the values. The output power delivered by the module is defined as the voltage at the output terminals multiplied by the output current. Using remote sense and trim can cause the output voltage to increase and consequently increase the power output of the module if output current remains unchanged. Always ensure that the output power of the module remains at or below the maximum rated power. Also be aware that if V<sub>o.set</sub> is below nominal value, P<sub>out.max</sub> will also decrease accordingly because I<sub>o.max</sub> is an absolute limit. Thus, P<sub>out.max</sub> = V<sub>o.set</sub> x I<sub>o.max</sub> is also an absolute limit.

## Output Capacitance

The CQB150W series converters provide unconditional stability with or without external capacitors. For good transient response, low ESR output capacitors should be located close to the point of load (<100mm). PCB design emphasizes low resistance and inductance tracks in consideration of high current applications. Output capacitors with their associated ESR values have an impact on loop stability and bandwidth. These converters are designed to work with load capacitance to see technical specifications.

**Remote On/Off circuit**

The converter remote On/Off circuit built-in on input side. The ground pin of input side Remote On/Off circuit is  $-V_{in}$  pin. Connection examples see below.

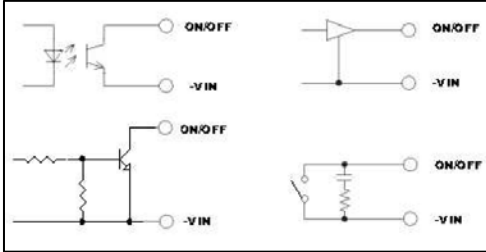

**Output Ripple and Noise**

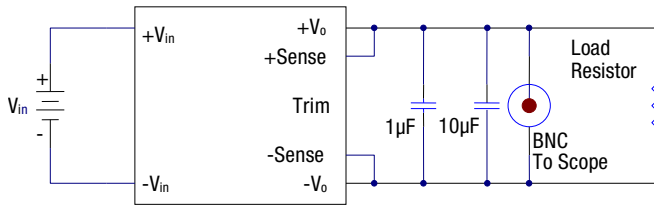

Output ripple and noise measured with 10uF aluminum and 1uF ceramic capacitor across output for 48Vout and with 10uF tantalum and 1uF ceramic capacitor for others. A 20 MHz bandwidth oscilloscope is normally used for the measurement. The conventional ground clip on an oscilloscope probe should never be used in this kind of measurement. This clip, when placed in a field of radiated high frequency energy, acts as an antenna or inductive pickup loop, creating an extraneous voltage that is not part of the output noise of the converter. In case of coaxial-cable/ BNC is not available, the noise pickup is eliminated by pressing scope probe ground ring directly against the  $-V_{out}$  terminal while the tip contacts the  $+V_{out}$  terminal. This makes the shortest possible connection across the output terminals.

**Series operation**

Series operation is possible by connecting the outputs two or more units. Connection is shown in below. The output current in series connection should be lower than the lowest rate current in each power module.

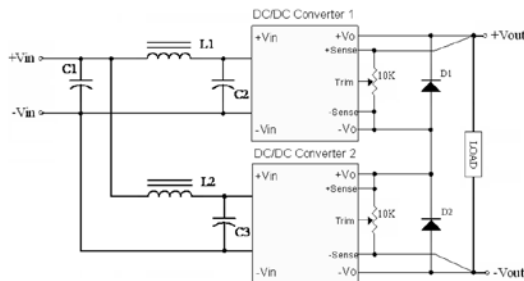

**Simple Series Operation Connect Circuit**

L1, L2: 1.0uH

C1, C2, C3: 220uF/100V ESR<0.035Ω

If the impedance of the input line is high, C1, C2, C3 capacitance must be more than above. Use more than the two recommended capacitor above in parallel when the ambient temperature becomes lower than  $-20^{\circ}\text{C}$ . It is recommended that Schottky diode (D1, D2) be connected across the output of each series connected converter, so that if one

converter shuts down for any reason, then the output stage won't be thermally overstressed. Without this external diode, the output stage of the shut-down converter could carry the load current provided by the other series converters, with its MOSFETs conducting through the body diodes. The MOSFETs could then be overstressed and fail. The external diode should be capable of handling the full load current for as long as the application is expected to run with any unit shut down. Series for  $\pm$ output operation is possible by connecting the outputs two units, as shown in the schematic below.

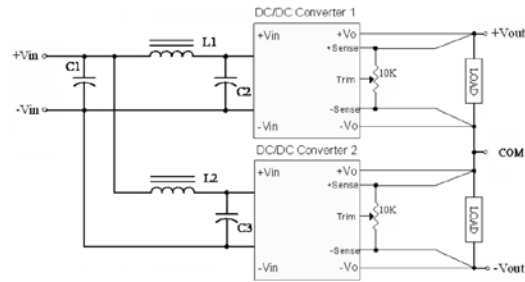

**Simple  $\pm$ Output Operation Connect Circuit**

L1, L2: 1.0uH

C1, C2, C3: 220uF/100V ESR<0.035Ω

If the impedance of the input line is high, C1, C2, C3 capacitance must be more than above. Use more than the two recommended capacitor above in parallel when the ambient temperature becomes lower than  $-20^{\circ}\text{C}$ .

**Parallel / Redundant Operation**

Parallel for redundancy operation is possible by connecting the units as shown in the schematic below. The current of each converter become unbalance by a slight difference of the output voltage. Make sure that the output voltage of units of equal value and the output current from each power supply does not exceed the rate current. It is suggested to use an external potentiometer to adjust output voltage from each power supply.

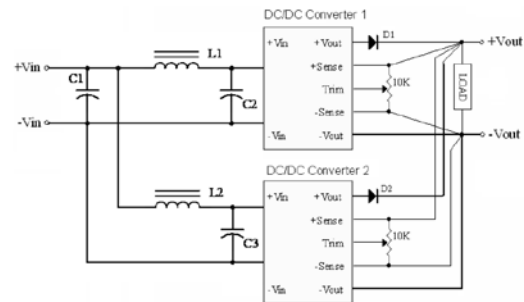

**Simple Redundant Operation Connect Circuit**

L1, L2: 1.0uH

C1, C2, C3: 220uF/100V ESR<0.035Ω

If the impedance of the input line is high, C1, C2, C3 capacitance must be more than above. Use more than the two recommended capacitor above in parallel when the ambient temperature becomes lower than  $-20^{\circ}\text{C}$ .

**SAFETY and EMC**

**Input Fusing and Safety Considerations**

This QB series of converters have no internal fuse. In order to achieve maximum safety and system protection, always use an input line fuse. We recommended a time delay fuse 30A time delay fuse for 24Vin models, and 15A for 48Vin models.. It is recommended that the circuit have a transient voltage suppressor diode (TVS) across the input terminal to protect the unit against surge or spike voltage and input reverse voltage (as shown).

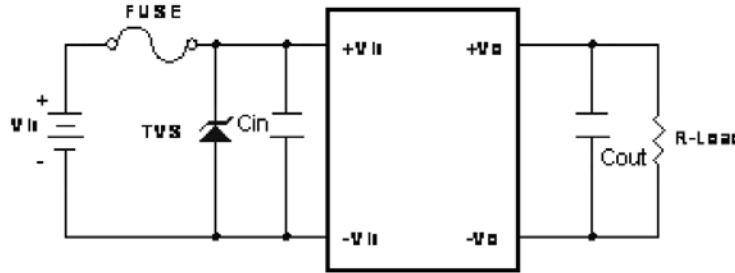

The external input capacitor  $C_{in}$  is required for this QB series in order to meet EN61000-4-4, EN61000-4-5. The capacitor is an aluminum capacitor type Nippon chemi-con KY series with value of 470uF/100V.

**EMC Considerations**

EMI Test standard: EN55022 / EN55032 Class A Conducted Emission

Test Condition: Input Voltage: Nominal, Output Load: Full Load

EMI and conducted noise meet EN55022 Class A:

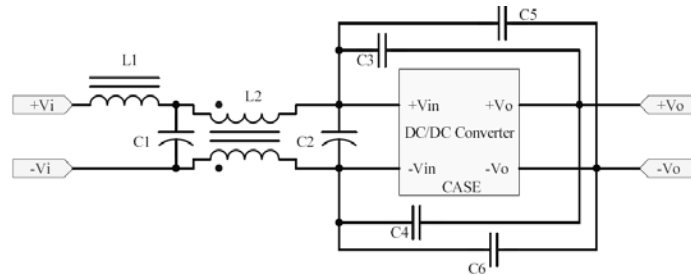

Circuit connection for conducted EMI Class A testing

Model No.	C1	C2	C3	C4	C5	C6	L1	L2
QB22S5-30	470µF/50V	470µF/50V	2200pF	N.C	N.C	2200pF	Short	0.5mH
QB22S12-12.5	470µF/50V	470µF/50V	2200pF	N.C	N.C	2200pF	Short	0.5mH
QB22S24-6.3	470µF/50V	470µF/50V	2200pF	N.C	N.C	2200pF	Short	0.5mH
QB22S28-5.4	470µF/50V	470µF/50V	2200pF	N.C	N.C	2200pF	Short	0.5mH
QB22S48-3.2	470µF/50V	470µF/50V	4700pF	N.C	N.C	4700pF	Short	0.5mH
QB22S5-30	470µF/50V	470µF/50V	2200pF	N.C	N.C	2200pF	Short	0.5mH
QB22S12-12.5	470µF/50V	470µF/50V	2200pF	N.C	N.C	2200pF	Short	0.5mH
QB22S24-6.3	470µF/50V	470µF/50V	2200pF	N.C	N.C	2200pF	Short	0.5mH
QB22S28-5.4	470µF/50V	470µF/50V	2200pF	N.C	N.C	2200pF	Short	0.5mH
QB22S48-3.2	470µF/50V	470µF/50V	4700pF	N.C	N.C	4700pF	Short	0.5mH

Note: C1, C2 are NIPPON CHEMI-CON KY series aluminum capacitors and C3, C4, C5, C6 are ceramic capacitors



**EMI and conducted noise meet EN55022 Class A**

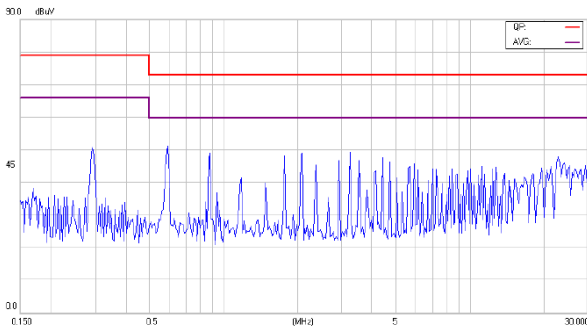

Class A conducted Line test for QB22S5-30

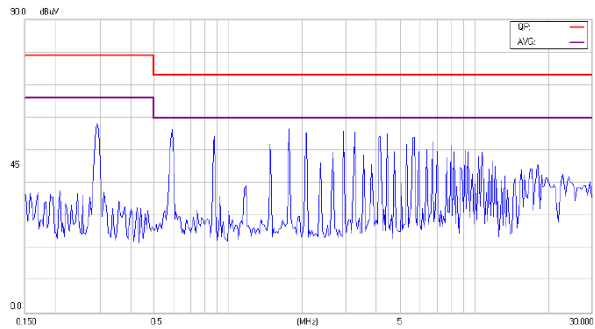

Class A conducted Nature test for QB22S5-30

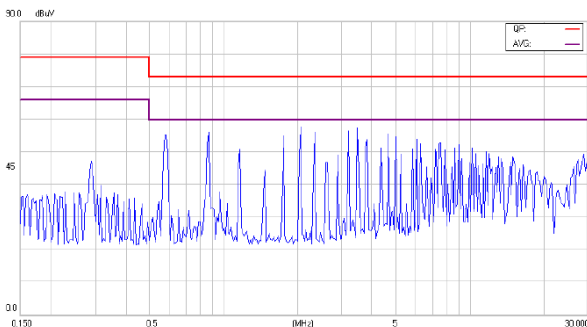

Conducted Class A of CQB150W-24S12 Line

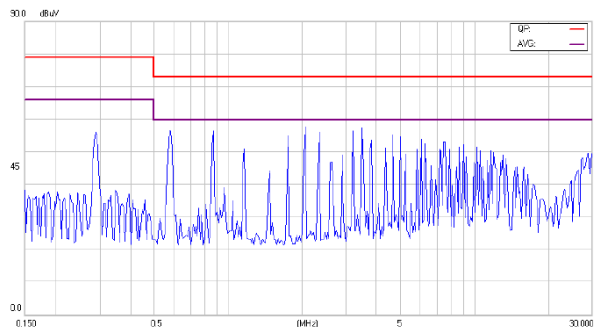

Conducted Class A of CQB150W-24S12 Nature

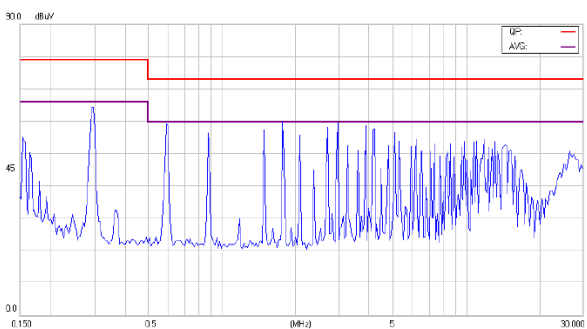

Class A conducted Line test for QB22S24-6.3

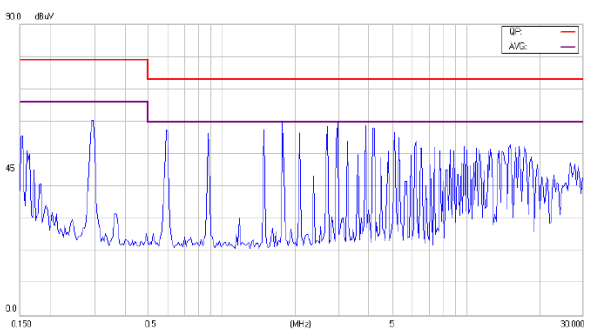

Class A conducted Nature test for QB22S24-6.3

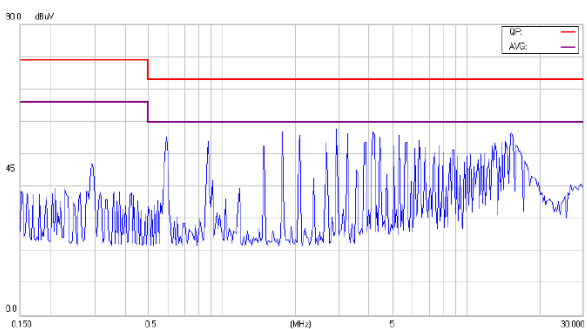

Class A conducted Line test for QB22S28-5.4

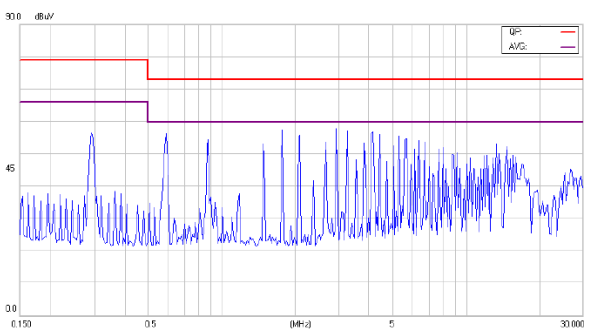

Class A conducted Nature test for QB22S28-5.4

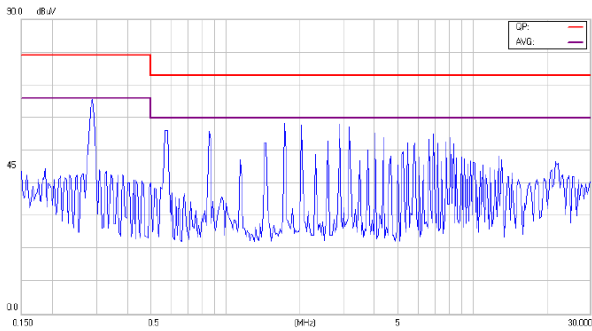

Class A conducted Line test for QB22S48-3.2

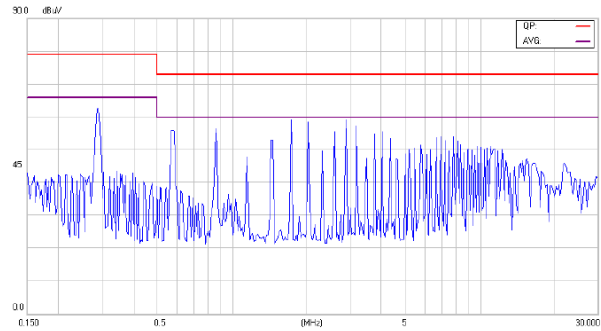

Class A conducted Nature test for QB22S48-3.2

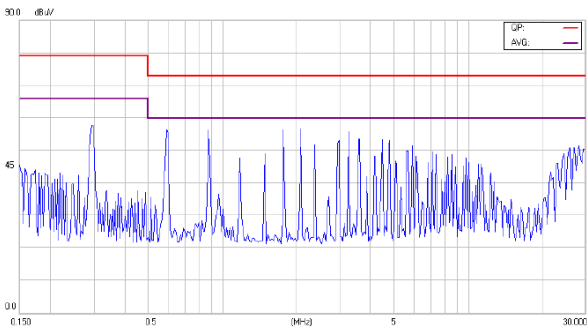

Class A conducted Line test for QB45S5-30

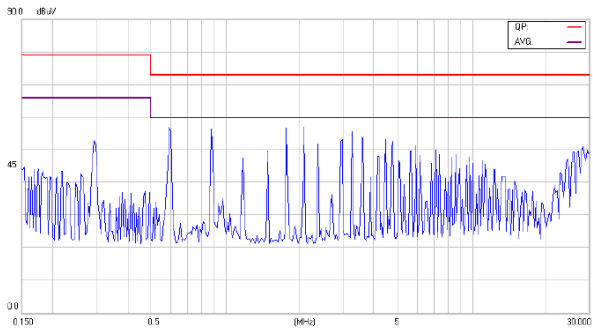

Class A conducted Nature test for QB45S5-30

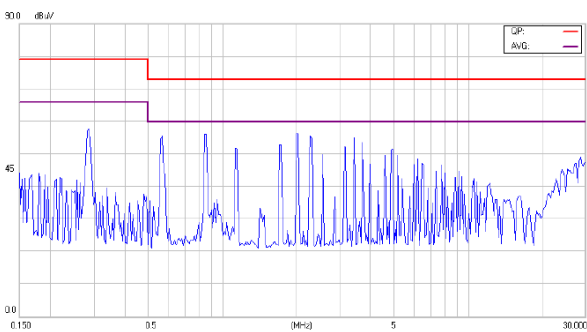

Class A conducted Line test for QB45S12-12.5

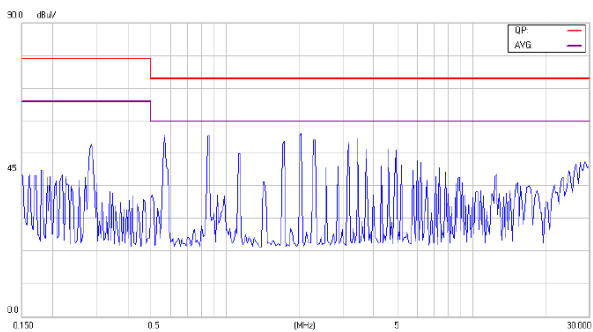

Class A conducted Nature test for QB45S12-12.5

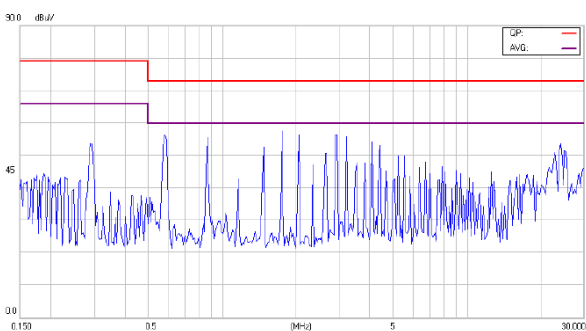

Class A conducted Line test for QB45S24-6.3

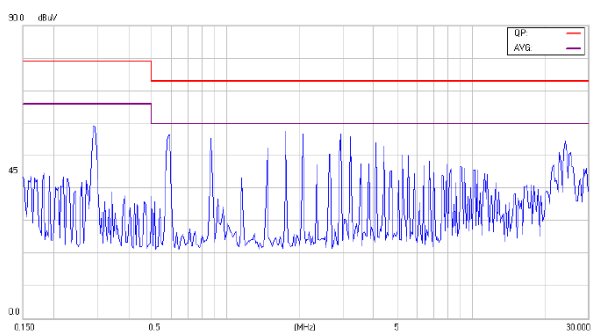

Class A conducted Nature test for QB45S24-6.3

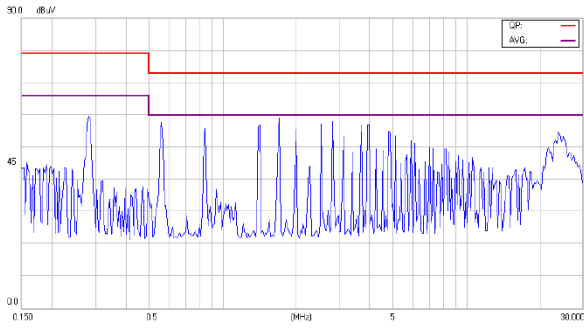

Class A conducted Line test for QB45S28-5.4

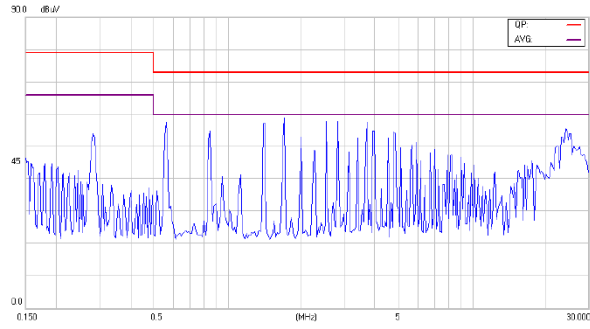

Class A conducted Nature test for QB45S24-5.4

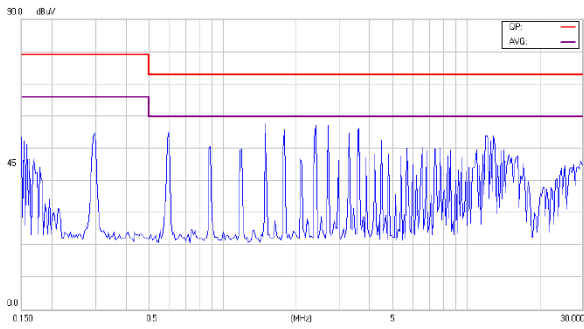

Class A conducted Line test for QB45S48-3.2

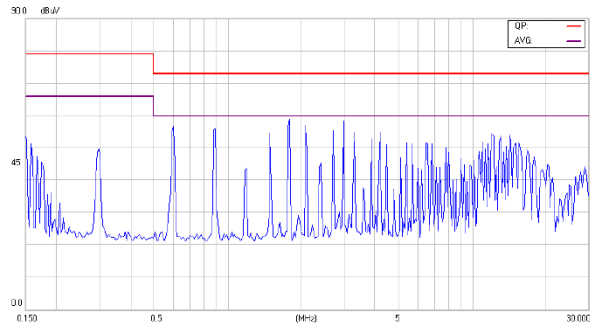

Class A conducted Nature test for QB45S48-3.2

**MECHANICAL SPECIFICATIONS**

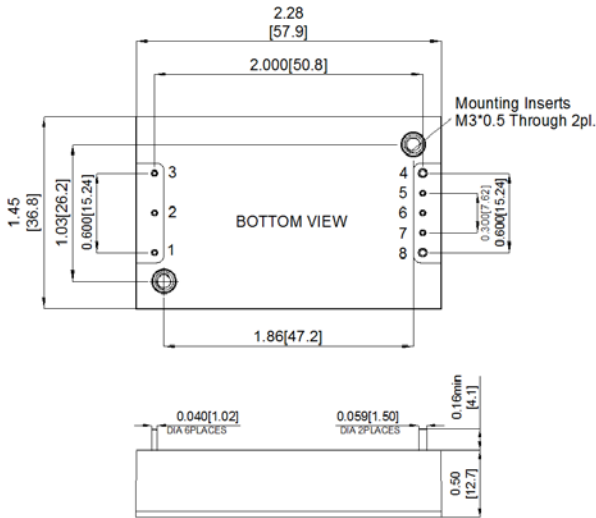

Note: All dimensions are in inches (millimeters). Tolerance: x.xx ±0.02 in. (0.5mm), x.xxx ±0.010 in. (0.25 mm) unless otherwise noted

**PIN CONNECTIONS**

PIN CONNECTIONS	
PIN	SINGLE OUTPUT
1	+ V Input
2	On/Off
3	- V Input
4	-V output
5	-Sense
6	Trim
7	+ Sense
8	+ V Output

**PART NUMBER ORDERING INFORMATION**

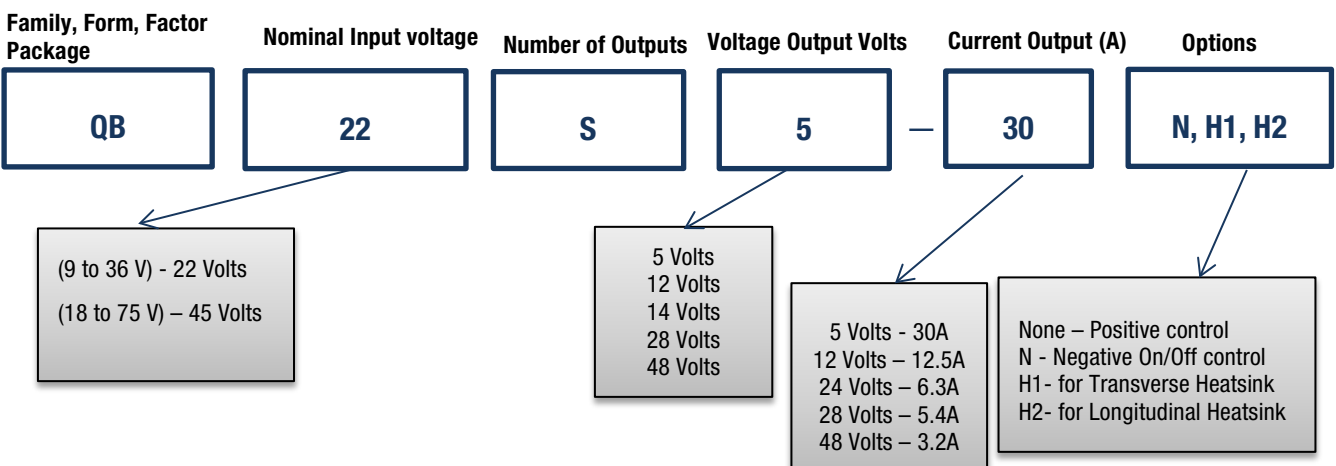

Note: For proper part ordering, enter option suffixes in order listed in table above