



**FEATURES**

- Isolated Output 60 Watts
- 4:1 Input Range (43 – 160 VDC)
- Regulated Outputs
- Efficiency to 92%
- Low No Load Power Consumption
- Remote On/Off
- Continuous Short Circuit Protection
- Up to 4km of Operating Altitude
- -40 °C to +105 °C
- Voltage/Current/Over-temperature Protection
- Quarter Brick Dimension
- Meet Industrial Standard
- Designed to meet UL60950-1 basic insulation

**PRODUCT OVERVIEW**

The QBR railway series offers 60 watts of output power housed in an industry standard quarter-brick package with high power density. This QBR series features wide input voltage range (4:1) from 43 to 160VDC (110 Volts nominal), high efficiency isolation of 3000VDC and provide a precise regulated voltage output.

All QBR models operate over the temperature range of – 40°C to +105°C. The modules offer Input under voltage lock out (UVLO), and are fully protected against output overvoltage conditions. All models have internal over current and continuous short circuit protection. The output voltage can be trimmed to the required voltage and the product includes remote on/off function.

This series provides efficiency up to 92% with low No-Load power consumption. The QBR series meet industrial standard and is the best choice for railway system, industrial, distributed power architectures, telecommunications, and mobile applications.

Please contact DATEL if your application requires different output voltage or any other special feature.

**APPLICATIONS:**

- Railway Systems
- Distributed Power Systems
- mobile equipment
- Telecommunications

**AVAILABLE OPTIONS**

- Customizable Input/ Output voltages
- Heatsink, customizable packaging
- UL/CSA60950-1

MODEL NUMBER	INPUT VOLTAGE	OUTPUT VOLTAGE	OUTPUT CURRENT		INPUT CURRENT		% EFFICIENCY	CAPACITOR MAX LOAD
			MIN	MAX	NO LOAD	FULL LOAD		
QBR101S5-12	43-160 VDC	5 VDC	0 mA	12 A	5 mA	600mA	91	6800µF
QBR101S12-5	43-160 VDC	12 VDC	0 mA	5 A	5 mA	593mA	92	3300µF
QBR101S15-4	43-160 VDC	15 VDC	0 mA	4 A	5 mA	606mA	90	3300µF
QBR101S24-2.5	43-160 VDC	24 VDC	0 mA	2.5 A	5 mA	606 mA	90	1200µF
QBR101S28-2.1	43-160 VDC	28 VDC	0 mA	2.1 A	5 mA	606 mA	90	1200µF
QBR101S48-1.2	43-160 VDC	48 VDC	0 mA	1.2 A	5 mA	613 mA	90	470µF

**BLOCK DIAGRAM**

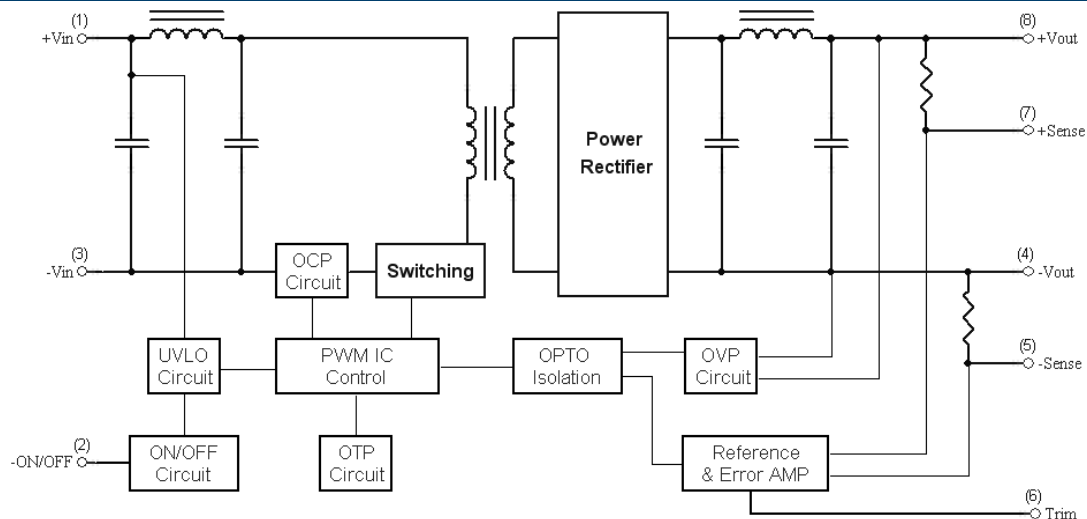

DATEL, Inc. 120 Forbes Boulevard, Suite 125, Mansfield MA 02048 USA • Tel (508)964-5131 • www.datel.com • e-mail:help@datel.com

### ABSOLUTE MAXIMUM RATINGS

PARAMETER	CONDITIONS	Model	Min.	Typical	Max.	Units
Input Voltage						
Continuous	DC	All	-0.3		160	Volts
Transient	100 ms, DC	All			180	Volts
Operating Case Temperature		All	-40		+105	°C
Storage Temperature		All	-55		+125	°C
Isolation Voltage	1 minute; input/output, input/case, DC	All	3000			Volts
	1 minute; output/case, DC	All	1500			

Stresses above the absolute maximum ratings can cause permanent damage to the device.

### FUNCTIONAL SPECIFICATIONS

The following specifications apply over the operating temperature range, under the following conditions  $T_A = +25^\circ\text{C}$  unless otherwise specified

#### INPUT CHARACTERISTICS

PARAMETER	CONDITIONS	Model	Min.	Typical	Max.	Units
Operating Input Voltage	DC	All	43	110	160	Volts
Input Under-voltage Lockout						
Turn-On Voltage Threshold	DC	All	40.5	42	42.5	Volts
Turn-Off Voltage Threshold	DC	All	37.5	38	39.5	Volts
Lockout Hysteresis Voltage	DC	All		3		Volts
Maximum Input Current	100% Load, $V_{in} = 43\text{V}$	All		1570		mA
No-Load Input Current	$V_{in} = \text{Nominal}$	All		5		
Inrush Current ( $I^2t$ )		All			0.1	A <sup>2</sup> s
Input Reflected Ripple Current	P-P thru 12 $\mu\text{H}$ inductor, 5Hz to 20MHz	All		30		mA

#### OUTPUT CHARACTERISTICS

PARAMETER	CONDITIONS	Device	Min.	Typical	Max.	Units
Output Voltage Set Point	$V_{in} = \text{Nominal } V_{in}$ , $I_o = I_{o\_max}$ , $T_c = 25^\circ\text{C}$ DC	$V_o = 5.0\text{V}$	4.925	5	5.075	Volts
		$V_o = 12\text{V}$	11.82	12	12.18	
		$V_o = 15\text{V}$	14.775	15	15.225	
		$V_o = 24\text{V}$	23.64	24	24.36	
		$V_o = 28\text{V}$	27.58	28	28.42	
		$V_o = 48\text{V}$	47.28	48	48.72	
Output Voltage Regulation						
Load Regulation	$I_o = I_{o\_min}$ to $I_{o\_max}$	All			$\pm 0.2$	%
Line Regulation	$V_{in} = \text{low line to high line}$	All			$\pm 0.2$	%
Temperature Coefficient	$T_C = -40^\circ\text{C}$ to $100^\circ\text{C}$	All			$\pm 0.03$	%/ $^\circ\text{C}$
Output Voltage Ripple and Noise (5Hz to 20MHz bandwidth)						
Peak-to-Peak	Full load, 10 $\mu\text{F}$ tantalum and 1.0 $\mu\text{F}$ ceramic capacitors	$V_o = 5.0\text{V}$			100	mV
		$V_o = 12 \& 15\text{V}$			150	
		$V_o = 24 \& 28\text{V}$			240	
		$V_o = 48\text{V}$			480	
RMS	Full load, 10 $\mu\text{F}$ solid tantalum and 1.0 $\mu\text{F}$ ceramic capacitors	$V_o = 5.0\text{V}$			40	mV
		$V_o = 12 \& 15\text{V}$			60	
		$V_o = 24 \& 28\text{V}$			100	
		$V_o = 48\text{V}$			200	

Operating Output Current Range		Vo=5.0V	0		12	A
		Vo=12V	0		5	
		Vo=15V	0		4	
		Vo=24V	0		2.5	
		Vo=28V	0		2.14	
		Vo=48V	0		1.25	
Output DC Current Limit Inception	Vo = 90% Nominal Output Voltage	All	110		165	%
Maximum Output Capacitance	Full load (resistive)	Vo=5.0V	0		6800	μF
		Vo=12V	0		3300	
		Vo=15V	0		3300	
		Vo=24V	0		1200	
		Vo=28V	0		1200	
		Vo=48V	0		470	

### DYNAMIC CHARACTERISTICS

PARAMETER	CONDITIONS	Model	Min.	Typical	Max.	Units
Output Voltage Current Transient						
Step Change in Output Current	75% to 100% of I <sub>o_max</sub>	All			±5	%
Setting Time (within 1% V <sub>out</sub> nominal)	d <sub>i</sub> /d <sub>t</sub> =0.1A/μs	All			250	μs
Turn-On Delay and Rise Time						
Turn-On Delay Time, From On/Off Control	V <sub>on/off</sub> to 10%V <sub>o_set</sub>	All		10		ms
Turn-On Delay Time, From Input	V <sub>in_min</sub> to 10%V <sub>o_set</sub>	All		15		ms
Output Voltage Rise Time	10%V <sub>o_set</sub> to 90%V <sub>o_set</sub>	All		10		ms

### EFFICIENCY

PARAMETER	CONDITIONS	Device	Min.	Typical	Max.	Units
100% Load	V <sub>in</sub> =Nominal V <sub>in</sub> , T <sub>c</sub> =25°C	Vo=5.0V		91		%
		Vo=12V		92		
		Vo=15V		90		
		Vo=24V		90		
		Vo=28V		90		
		Vo=48V		89		

## ISOLATION CHARACTERISTICS

PARAMETER	CONDITIONS	Model	Min.	Typical	Max.	Units
Isolation Voltage	1 minute; input/output, input/case,	All			3000	Volts
	1 minute; output/case	All			1500	
Isolation Resistance		All	10			MΩ
Isolation Capacitance		All		1000		pF

## FEATURE CHARACTERISTICS

PARAMETER	CONDITIONS	Model	Min.	Typical	Max.	Units
Switching Frequency		All		200		KHz
On/Off Control, Positive Remote On/Off logic						
Logic Low (Module Off)	$V_{on/off}$ at $I_{on/off}=1.0mA$	All			1.2	V
Logic High (Module On)	$V_{on/off}$ at $I_{on/off}=0.0uA$	All	3.5 or Open Circuit		75	V
On/Off Control, Negative Remote On/Off logic						
Logic High (Module Off)	$V_{on/off}$ at $I_{on/off}=0.0uA$	All	3.5 or Open Circuit		75	V
Logic Low (Module On)	$V_{on/off}$ at $I_{on/off}=1.0mA$	All			1.2	V
On/Off Current (for both remote on/off logic)	$I_{on/off}$ at $V_{on/off}=0.0V$	All		0.3	1	mA
Leakage Current (for both remote on/off logic)	Logic High, $V_{on/off}=15V$	All			30	μA
Off Converter Input Current	Shutdown input idle current	All		2	5	mA
Output Voltage Trim Range	$P_{out}=\text{max rated power}$	All	-10		+10	%
Output Over Voltage Protection		All	115	125	140	%
Over-Temperature Shutdown		All		110		°C

## GENERAL SPECIFICATIONS

PARAMETER	NOTES and CONDITIONS	Device	Min.	Typical	Max.	Units
MTBF	$I_o=100\%$ of $I_{o\ max}$ ; $T_a=25^\circ C$ per MIL-HDBK-217F	All		650		K hours
Weight		All		61.5		grams
Safety	UL60950-1 2 <sup>nd</sup> (Basic Insulation)					
EMC (see EMI section)	EN50121-3-2 (with External Filter)					
EMI (with External Filter)	EN55022 Class B					
	EN55011 Class A					
ESD	EN61000-4-2 Air $\pm 8000V$ Perf. Criteria A					
	EN61000-4-2 Contactr $\pm 6KV$ Perf. Criteria A					
Radiated Immunity	EN61000-4-3 20V/m Perf. Criteria A					
Fast Transient	EN61000-4-4 $\pm 2KV$ Perf. Criteria A					
Surge	EN61000-4-5 $\pm 1KV$ Perf. Criteria B					
Conducted Immunity	EN61000-4-6 10Vr.m.s Perf. Criteria A					
Shock/Vibration	Meets EN61373, MIL-STD-810F					
Humidity	95% RH max. Non Condensing					

**POWER DERATING**

The operating case temperature range of the QBR series is -40°C to +105°C. When operating the QBR series, proper derating or cooling is needed. The maximum case temperature under any operating condition should not exceed + 105°C.

Forced Convection Power De-rating without Heat Sink

Example (without heatsink):

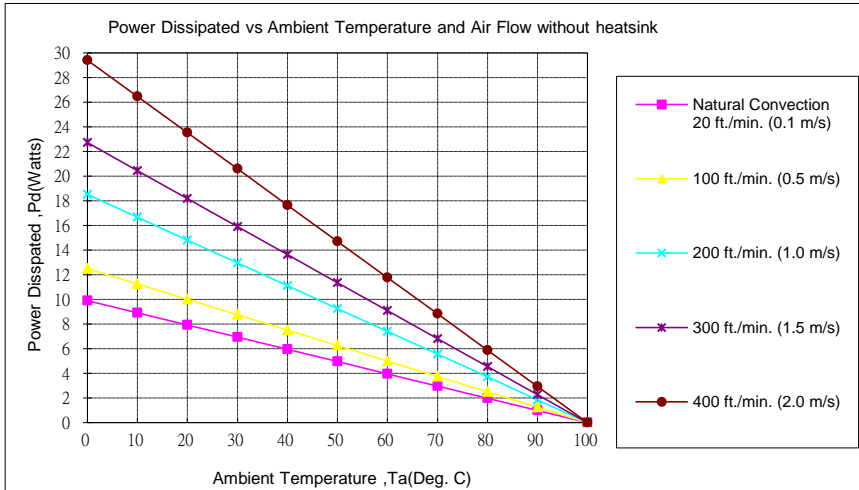

AIR FLOW RATE	TYPICAL R <sub>ca</sub>
Natural Convection 20ft. /min. (0.1 m/s)	10.1 °C/W
100 ft./min. (0.5m/s)	8.0 °C/W
200 ft./min. (1.0m/s)	5.4 °C/W
300 ft./min. (1.5m/s)	4.4 °C/W
400 ft./min. (2.0m/s)	3.4 °C/W

What is the minimum airflow necessary for a QBR101S5-12 operating at nominal line voltage, an output current of 12A, and a maximum ambient temperature of 50°C?

**Solution:**

**Given:**

$$V_{in}=110V_{dc}, V_o=5V_{dc}, I_o=12 A$$

**Determine Power dissipation (P<sub>d</sub>):**

$$P_d = P_i - P_o = P_o(1-\eta)/\eta$$

$$P_d = 5 \times 12 \times (1-0.91)/0.91 = 5.93 \text{ Watts}$$

**Determine airflow:**

$$\text{Given: } P_d = 5.93W \text{ and } T_a = 50^\circ C$$

**Check Power Derating curve:**

Minimum airflow= 100 ft./min.

**Verify:**

Maximum temperature rise is

$$\Delta T = P_d \times R_{ca} = 5.93W \times 8.0 = 47.44^\circ C.$$

Maximum case temperature is

$$T_c = T_a + \Delta T = 97.44^\circ C < 105^\circ C.$$

**Where:**

The R<sub>ca</sub> is thermal resistance from case to ambient environment.

T<sub>a</sub> is ambient temperature and T<sub>c</sub> is case temperature.

Example (with heatsink M-C421)

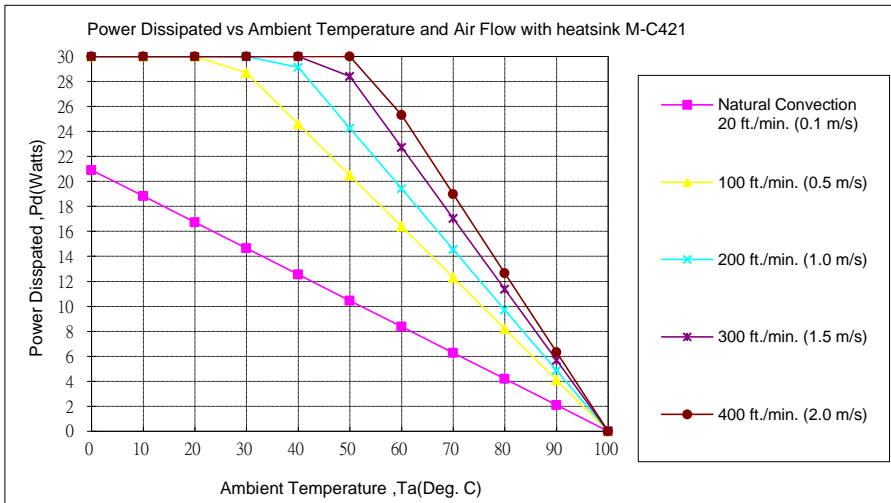

AIR FLOW RATE	TYPICAL R <sub>ca</sub>
Natural Convection 20ft./min. (0.1m/s)	4.78 °C/W
100 ft./min. (0.5m/s)	2.44 °C/W
200 ft./min. (1.0m/s)	2.06 °C/W
300 ft./min. (1.5m/s)	1.76 °C/W
400 ft./min. (2.0m/s)	1.58 °C/W

What is the minimum airflow necessary for a QBR101S12-5 operating at nominal line voltage, an output current of 5A, and a maximum ambient temperature of 60°C?

**Solution:**

**Given:**

$$V_{in}=110V_{dc}, V_0=12V_{dc}, I_0=5 A$$

**Determine Power dissipation (P<sub>d</sub>):**

$$P_d = P_i - P_o = P_o(1-\eta)/\eta$$

$$P_d = 12 \times 5 \times (1-0.92)/0.92 = 5.22 \text{ Watts}$$

**Determine airflow:**

$$\text{Given: } P_d = 5.22 \text{ W and } T_a = 60^\circ\text{C}$$

**Check above Power de-rating curve:**

$$P_d < 8.4 \text{ W, Natural Convection}$$

**Verify:**

Maximum temperature rise is

$$\Delta T = P_d \times R_{ca} = 5.22 \times 4.78 = 24.95^\circ\text{C}$$

$$\text{Maximum case temperature is } T_c = T_a + \Delta T = 84.95^\circ\text{C} < 105^\circ\text{C}$$

**Where:**

The R<sub>ca</sub> is thermal resistance from case to ambient environment.

T<sub>a</sub> is ambient temperature and T<sub>c</sub> is case temperature.

**QUARTER BRICK HEAT SINKS:**

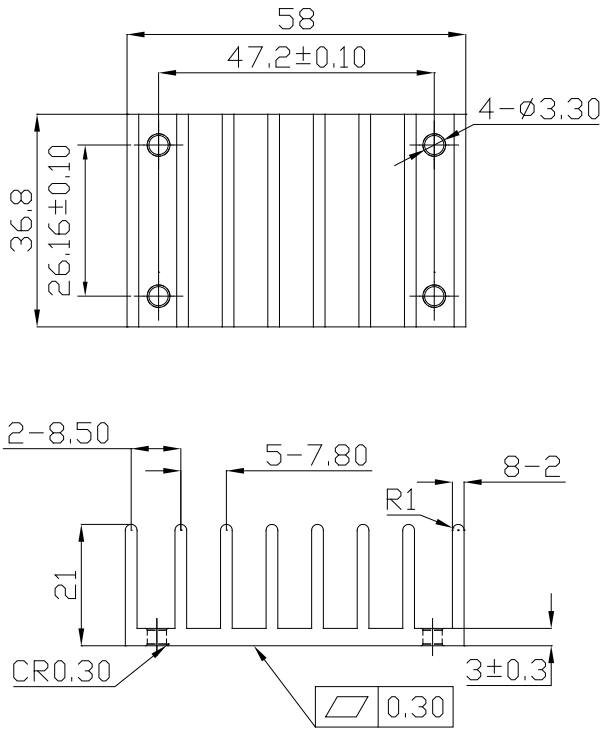

**M-C421 (G6620510201)**  
**Transverse Heat Sink**

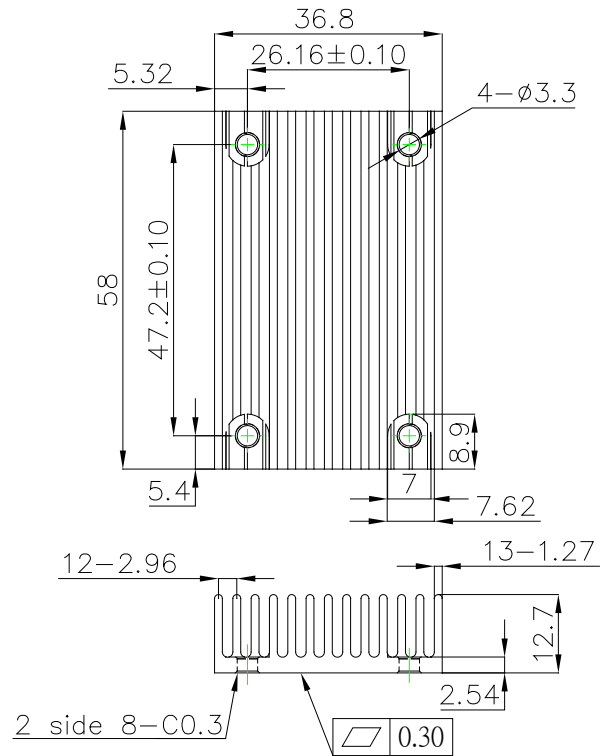

**M-C488 (G6620570202)**  
**Longitudinal Heat Sink**

All Dimensions in mm

Rca: 4.78°C/W (typ.), At natural convection  
2.44°C/W (typ.), At 100LFM  
2.06°C/W (typ.), At 200LFM  
1.76°C/W (typ.), At 300LFM  
1.58°C/W (typ.), At 400LFM

Rca: 5.61°C/W (typ.), At natural convection  
4.01°C/W (typ.), At 100LFM  
3.39°C/W (typ.), At 200LFM  
2.86°C/W (typ.), At 300LFM  
2.49°C/W (typ.), At 400LFM

THERMAL PAD: SZ 35.8\*56.9\*0.25 mm (G6135041041)  
SCREW: SMP+SW M3\*8L (G75A1300322)

**EFFICIENCY vs. LOAD**

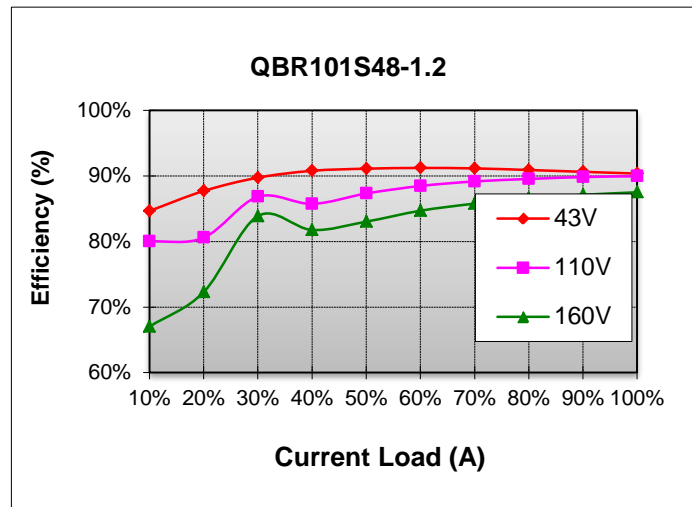
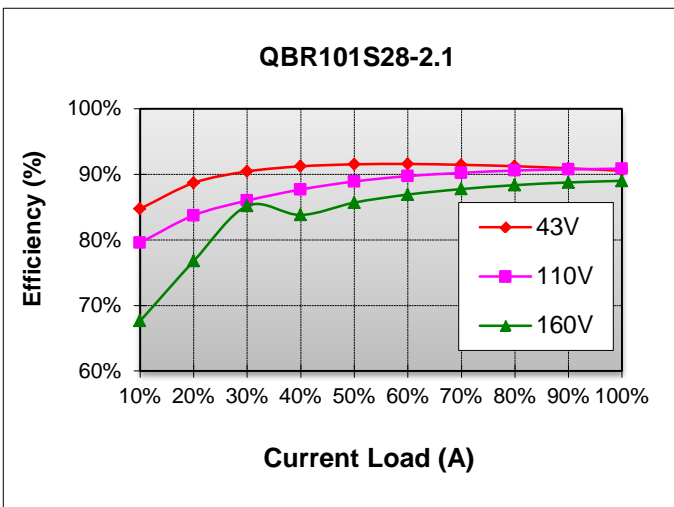
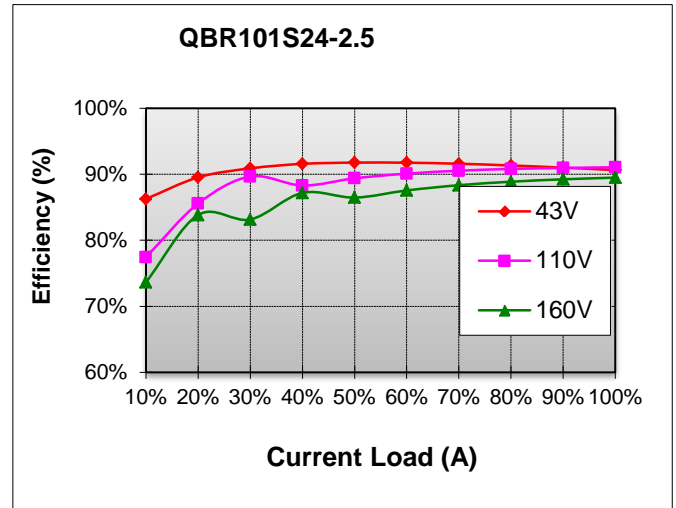
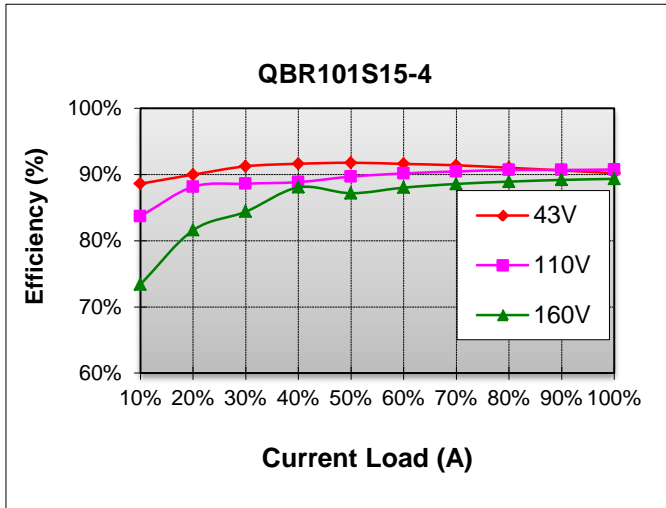
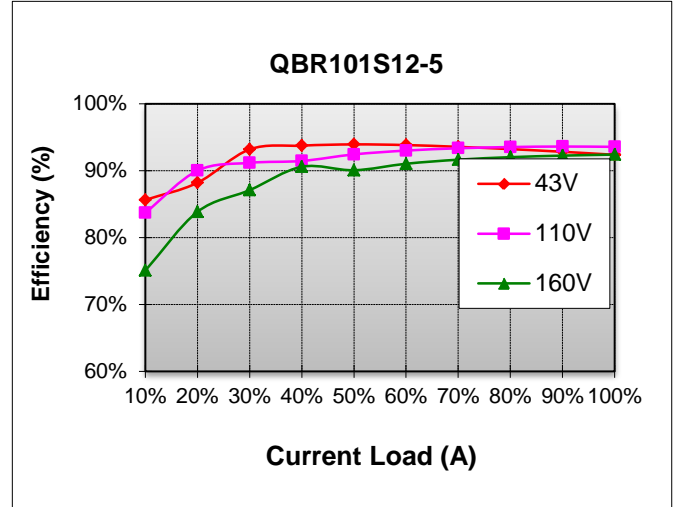
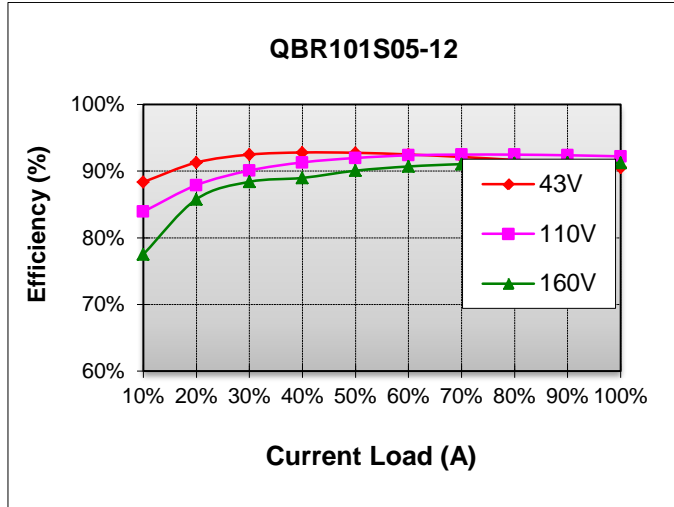



### Operating Temperature Range

The QBR series converters can be operated over a wide case temperature range of -40°C to +105°C. Consideration must be given to the derating curves when maximum power is drawn from the converter. The maximum power drawn from open half brick models is influenced by multiple factors, such as:

- Input voltage range
- Output load current
- Forced air or natural convection

### Output Voltage Adjustment

The next page describes in detail how to trim the output voltage with respect to its set point. The output voltage on all models is adjustable within the range of +10% to -10%.

### Over Current Protection

All models have internal over current and continuous short circuit protection. Once the fault condition is removed, the unit will operate normally. The converter will go into hiccup mode protection once the point of current limit inception is reached.

### Output Overvoltage Protection

The output overvoltage protection consists of circuitry that internally limits the output voltage. If more accurate output over voltage protection is required then an external circuit can be used via the Remote On/Off pin.

### Remote On/Off

The QBR series allows the user to switch the module on and off electronically with the remote on/off feature. All models are available in "positive logic" and "negative logic" (optional) versions. The converter turns on if the remote on/off pin is high (>3.5Vdc or open circuit). Setting the pin low (<1.2Vdc) will turn the Converter off. The signal level of the remote on/off input is defined with respect to ground. If not using the remote on/off pin, leave the pin open (converter will be on). Models with part number suffix "N" are the "negative logic" remote on/off version. The unit turns off if the remote on/off pin is high (>3.5Vdc or open circuit). The converter turns on if the on/off pin input is low (<1.2Vdc). Note that the converter is off by default.

### UVLO (Under voltage Lock Out)

Input under voltage lockout is standard on the QBR unit. The unit will shut down when the input voltage drops below a threshold, and the unit will operate when the input voltage goes above the upper threshold.

### Over Temperature Protection

These modules have an over temperature protection circuit to safeguard against thermal damage. Shutdown occurs with the maximum case reference temperature is exceeded. The module will restart when the case temperature falls below over temperature shutdown threshold.

### PCB Foot print, Recommended Layout, and Soldering Information

The end user of the converter must ensure that other components and metal in the vicinity of the converter meet the spacing requirements to which the system is approved. Low resistance and low inductance PCB layout traces should be used where possible. Careful consideration must also be given to proper low impedance tracks between power module, input and output grounds. The recommended footprints and

soldering profiles are shown in the next two figures

Lead Free Wave Soldering Profile

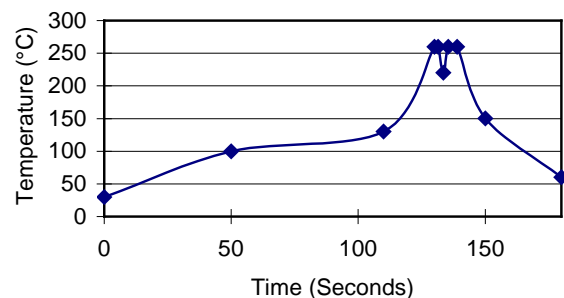

Note :

1. Soldering Materials: Sn/Cu/Ni
2. Ramp up rate during preheat: 1.4 °C/Sec (From + 50°C to +100°C)
3. Soaking temperature: 0.5 °C/Sec (From +100°C to + 130°C), 60 ± 20 seconds
4. Peak temperature: +260°C, above+ 250°C 3~6 Seconds
5. Ramp up rate during cooling: -10.0 °C/Sec (From+ 260°C to +150°C)

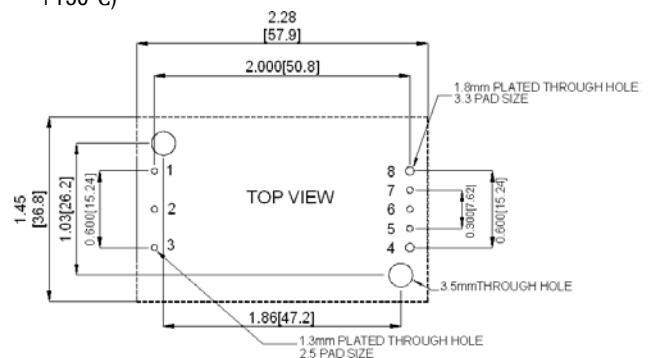

### Convection Requirements for Cooling

To predict the approximate cooling needed for the Quarter brick module, refer to the power derating curves. These derating curves are approximations of the ambient temperatures and airflows required to keep the power module temperature below its maximum rating. Once the module is assembled in the actual system, the module's temperature should be monitored to ensure it does not exceed +100°C as measured at the center of the top of the case (thus verifying proper cooling).

### Thermal Considerations

The power module operates in a variety of thermal environments; however, sufficient cooling should be provided to help ensure reliable operation of the unit. Heat is removed by conduction, convection, and radiation to the surrounding environment. The power output of the module should not be allowed to exceed rated power ( $V_{o\_set} \times I_{o\_max}$ ). The power modules have through-threaded, M3 x0.5 mounting holes, which enable heat sinks or cold plates to be attached to the module. Thermal de-rating with heat sinks is expressed by using the overall thermal resistance of the module ( $R_{ca}$ ).

**TEST SET-UP**

The basic test set-up to measure parameters such as efficiency and load regulation is shown below. When testing the modules under any transient conditions please ensure that the transient response of the source is sufficient to power the equipment under test. We can calculate:

- Efficiency
- Load regulation and line regulation.

The value of efficiency is defined as:

$$\eta = \frac{V_o \times I_o}{V_{in} \times I_{in}} \times 100\%$$

Where:

$V_o$  is output voltage,  
 $I_o$  is output current,  
 $V_{in}$  is input voltage,  
 $I_{in}$  is input current.

The value of load regulation is defined as:

$$\text{Load.reg} = \frac{V_{FL} - V_{NL}}{V_{NL}} \times 100\%$$

Where:

$V_{FL}$  is the output voltage at full load  
 $V_{NL}$  is the output voltage at no load

The value of line regulation is defined as:

$$\text{Line.reg} = \frac{V_{HL} - V_{LL}}{V_{LL}} \times 100\%$$

Where:

$V_{HL}$  is the output voltage of maximum input voltage at full load.  
 $V_{LL}$  is the output voltage of minimum input voltage at full load.

trim pin and +Vo for trim-down. The output voltage trim range is  $\pm 10\%$ . This is shown:

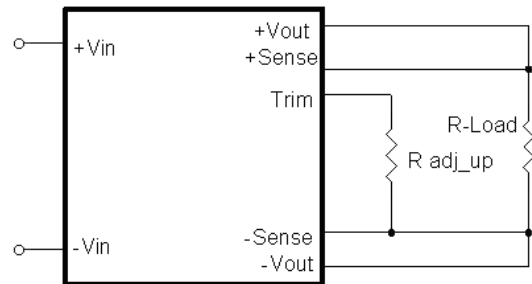

Trim-up Voltage Setup

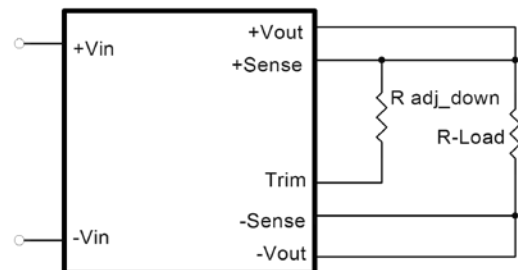

Trim-down Voltage Setup

V <sub>out</sub> (V)	A	B	C	D
5V	2.32	0	4.75	4.75
12V	9.1	0.4	5.8	39
15V	12	0.42	6.1	56
24V	20	0.44	6.4	100
28V	23.7	0.44	6.5	120
48V	43.2	0.46	6.6	240

Trim Resistor Values

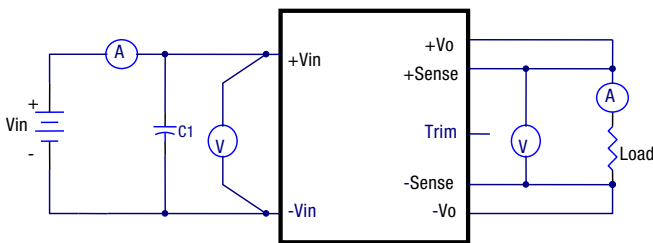

QBR Series Test Setup

**Output Voltage Adjustment**

Output may be externally trimmed ( $\pm 10\%$ ) with a fixed resistor or an external trim pot as shown (optional). Model specific formulas for calculating trim resistors are available upon request as a separate document.

The value of  $R_{trim\_up}$  defined as:

$$R_{trim\_up} = \frac{A \times (2.5 - B)}{V_o - V_{o\_nom}} - C \quad (K\Omega)$$

Where:

$R_{trim\_up}$  is the external resistor in  $K\Omega$ .  
 $V_{o\_nom}$  is the nominal output voltage.  
 $V_o$  is the desired output voltage.  
A, B and C are internal components.

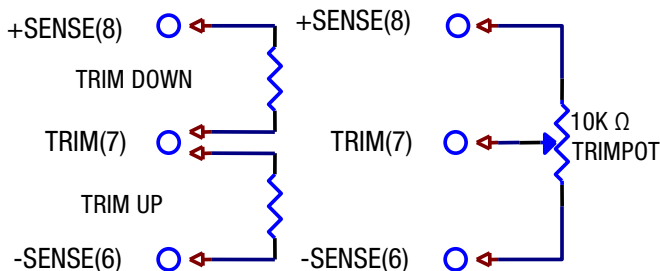

In order to trim the voltage up or down, one needs to connect the trim resistor either between the trim pin and -Vo for trim-up or between

For example, to trim-up the output voltage of 12V module (QBR101S12-5) by 5% to 12.6V,  $R_{trim\_up}$  is calculated as follows:

$$V_o - V_{o\_nom} = 12.6 - 12 = 0.6V$$

$$A = 9.1$$

$$B = 0.4$$

$$C = 5.8$$

$$R_{trim\_up} = \frac{9.1 \times (2.5 - 0.4)}{0.6} - 5.8 = 26.05 \text{ (K}\Omega\text{)}$$

The value of  $R_{trim\_down}$  defined as:

$$R_{trim\_down} = \frac{A \times (V_o - 2.5)}{V_{o\_nom} - V_o} - D \text{ (K}\Omega\text{)}$$

Where:

$R_{trim\_down}$  is the external resistor in K $\Omega$ .  
 $V_{o\_nom}$  is the nominal output voltage.  
 $V_o$  is the desired output voltage.  
 A and D are internal components.

For example: to trim-down the output voltage of 12V module (QBR101S12-5) by 5% to 11.4V,  $R_{trim\_down}$  is calculated as follows:

$$V_{o\_nom} - V_o = 12 - 11.4 = 0.6 V$$

$$A = 9.1$$

$$D = 39$$

$$R_{trim\_down} = \frac{9.1 \times (11.4 - 2.5)}{0.6} - 39 = 95.98 \text{ (K}\Omega\text{)}$$

### Output Remote Sensing

The QBR series converter has the capability to remotely sense both lines of its output. This feature moves the effective output voltage regulation point from the output of the unit to the point of connection of the remote sense pins. This feature automatically adjusts the real output voltage of the QBR series in order to compensate for voltage drops in distribution and maintain a regulated voltage at the point of load. The remote-sense voltage range is:  $[(+V_{out}) - (-V_{out})] - [(+Sense) - (-Sense)] \leq 10\%$  of  $V_{o\_nominal}$

If the remote sense feature is not to be used, the sense pins should be connected locally. The +Sense pin should be connected to the +Vout pin at the module and the -Sense pin should be connected to the -Vout pin at the module. This is shown in the schematic below.

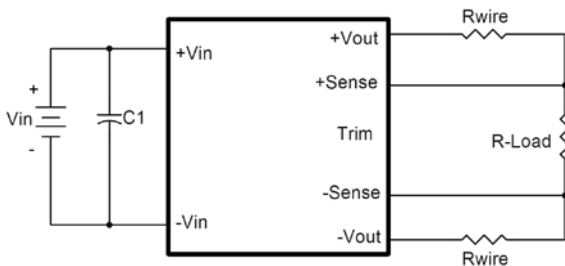

**Note:**

Although the output voltage can be varied (increased or decreased) by both remote sense and trim, the maximum variation for the output voltage is the larger of the two values not the sum of the values. The output power delivered by the module is defined as the voltage at the output terminals multiplied by the output current. Using remote sense and trim can cause the output voltage to increase and consequently increase the power output of the module if output current remains unchanged. Always ensure that the output power of the module remains at or below the maximum rated power. Also be aware that if  $V_{o\_set}$  is below nominal value,  $P_{out\_max}$  will also decrease accordingly

because  $I_{o\_max}$  is an absolute limit. Thus,  $P_{out\_max} = V_{o\_set} \times I_{o\_max}$  is also an absolute limit.

### Output Ripple and Noise

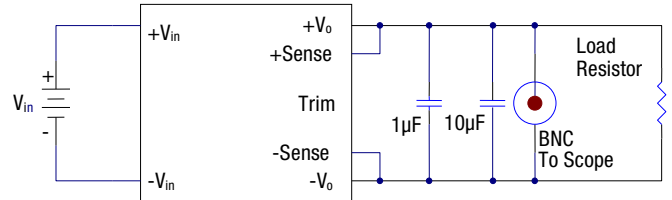

Output ripple and noise is measured with 10µF tantalum and 1µF ceramic capacitors across the output.

### Output Capacitance

The QBR series converters provide unconditional stability with or without external capacitors. For good transient response, low ESR output capacitors should be located close to the point of load. PCB design emphasizes low resistance and inductance tracks in consideration of high current applications. Output capacitors with their associated ESR values have an impact on loop stability and bandwidth. DATEL converters are designed to work with load capacitance to meet the technical specification.

**SAFETY and EMC**

**Input Fusing and Safety Considerations**

The QBR series converters have no internal fuse. In order to achieve maximum safety and system protection, always use an input line fuse. We recommended a time delay fuse 2A. It is recommended that the circuit have a transient voltage suppressor diode (TVS) across the input terminal to protect the unit against surge or spike voltage and input reverse voltage (as shown).

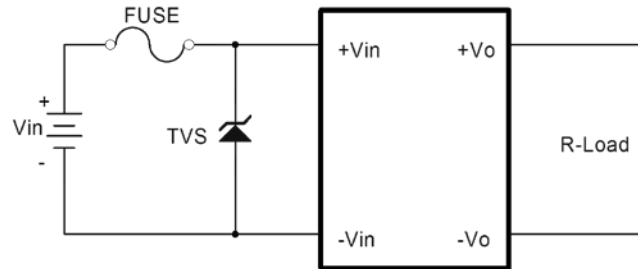

**EMC Considerations**

- (1) EMI Test standard: EN55022 Class B Conducted Emission  
Test Condition: Input Voltage: Nominal, Output Load: Full Load

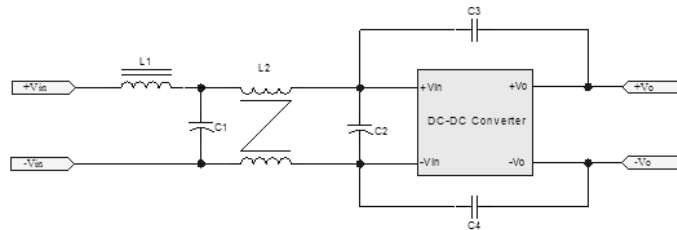

Model No.	C1	C2	C3	C4	L1	L2
QBR101S5-12	220µF/200V YXF	220µF/200V YXF	2200pF	2200pF	38uH	1mH
QBR101S12-5	220µF/200V YXF	220µF/200V YXF	2200pF	2200pF	38uH	1mH
QBR101S15-4	220µF/200V YXF	220µF/200V YXF	2200pF	2200pF	38uH	1mH
QBR101S24-2.5	220µF/200V YXF	220µF/200V YXF	2200pF	2200pF	Short Circuit	1mH
QBR101S28-2.14	220µF/200V YXF	220µF/200V YXF	2200pF	2200pF	Short Circuit	1mH
QBR101S48-1.25	220µF/200V YXF	220µF/200V YXF	2200pF	2200pF	Short Circuit	1mH

Note: C1, C2 Aluminum Capacitors and C3, C4 Ceramic Capacitors

**EMI and conducted noise meet EN55022 Class B**

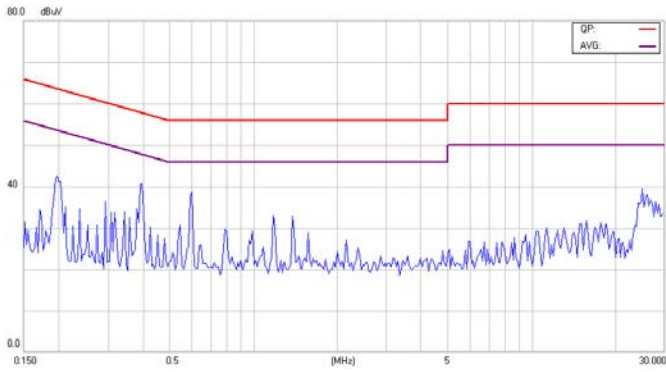

Class B test conducted for QBR101S5-12

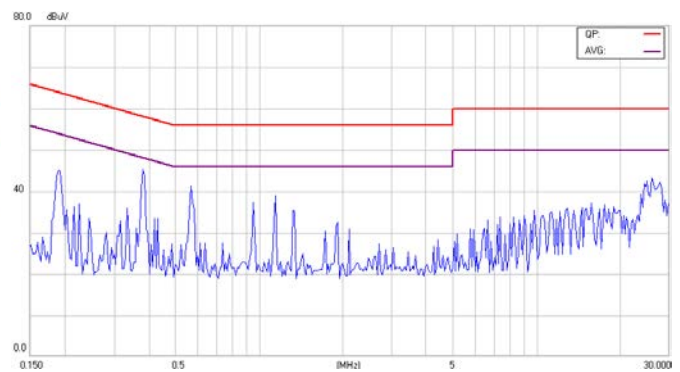

Class B test conducted for QBR101S12-5

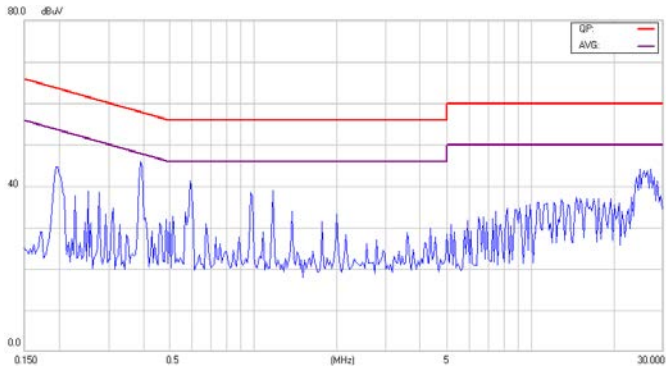

Class B test conducted for QBR101S15-4

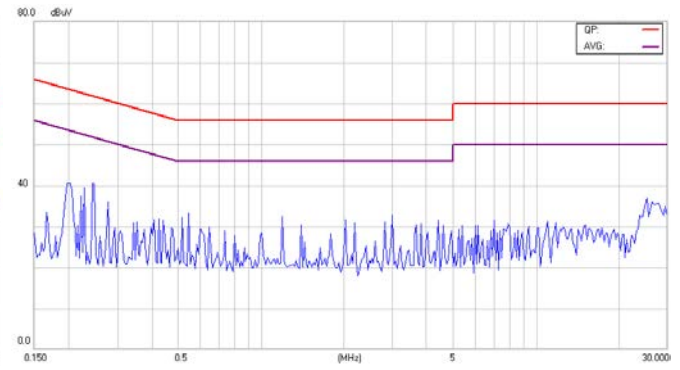

Class B test conducted for QBR101S24-2.5

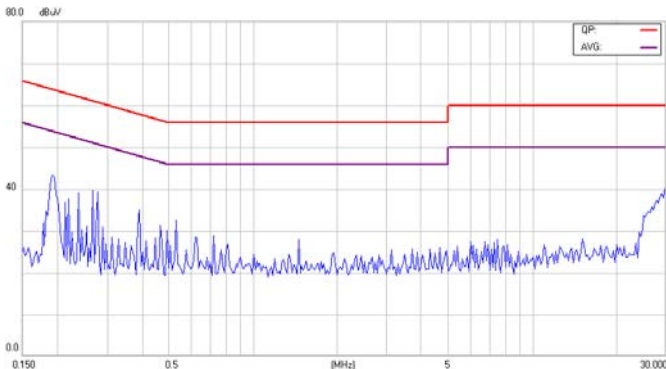

Class B test conducted for QBR101S28-2.14

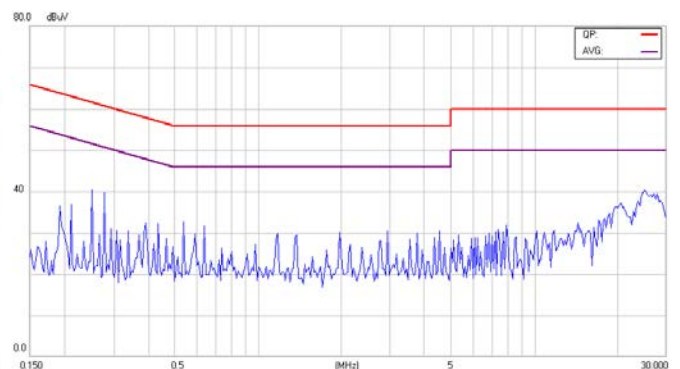

Class B test conducted for QBR101S48-1.25

(2) EMI Test standard: EN50121-3-2 (EN55011 Class A Conducted & Radiated Emission)

Test Condition: Input Voltage: Nominal, Output Load: Full Load

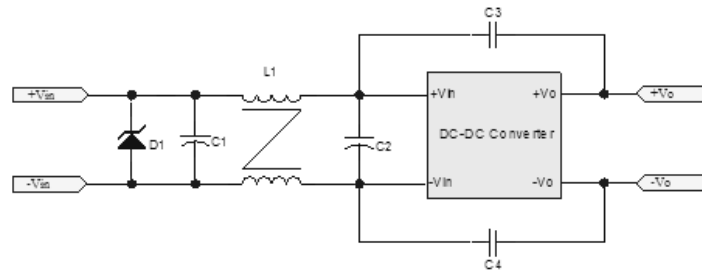

Model No.	D1	C1	C2	C3	C4	L1
QBR Series	1.5KE180A Littelfuse	220μF/200V YXF	220μF/200V YXF	2200pF	2200pF	1mH

Note: C1, C2 Aluminum Capacitors and C3, C4 Ceramic Capacitors



**EMI and conducted noise meet EN55011 Class A**

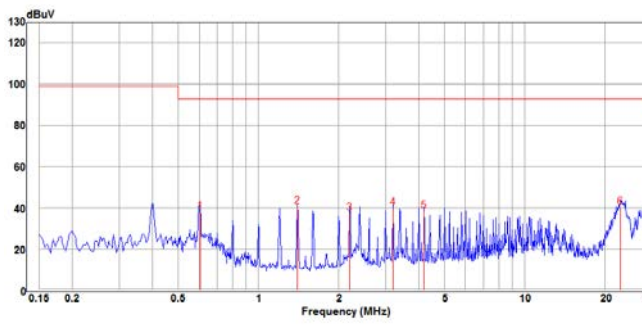

Class A test conducted for QBR101S5-12

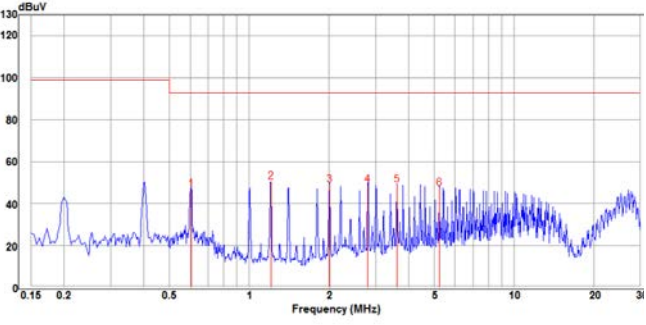

Class A test conducted for QBR101S12-5

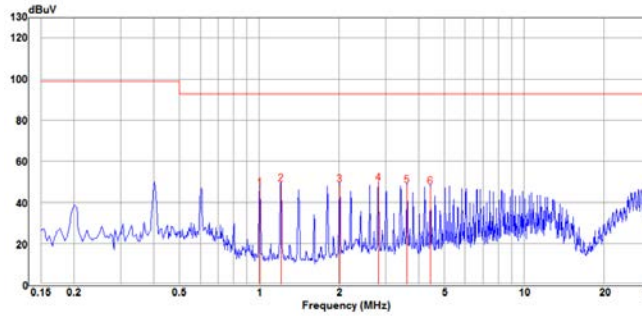

Class A test conducted for QBR101S15-4

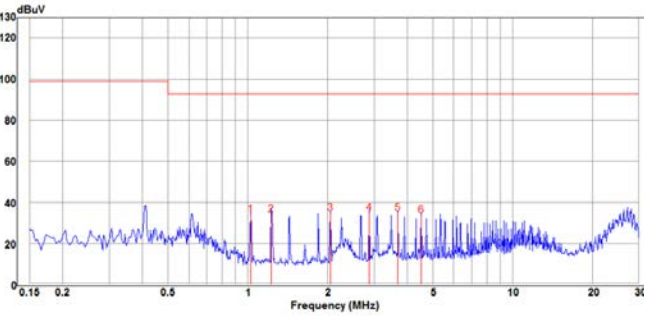

Class A test conducted for QBR101S24-2.5

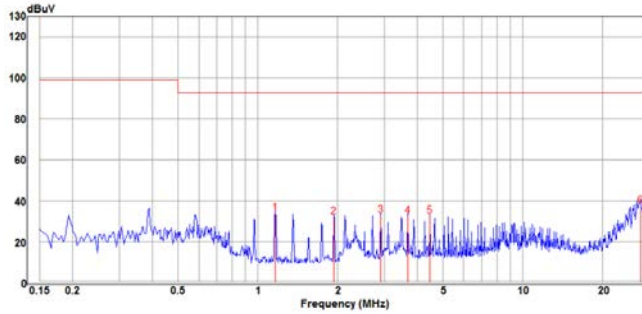

Class A test conducted for QBR101S28-2.14

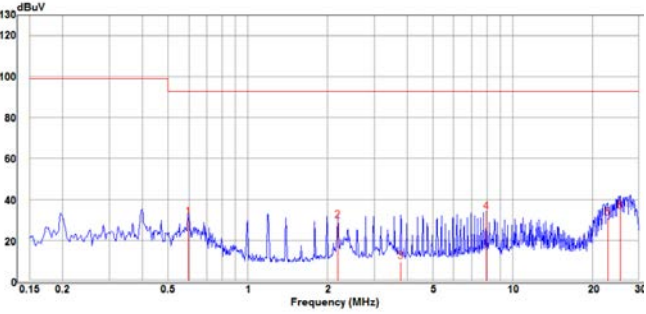

Class A test conducted for QBR101S48-1.25

**SUGGESTED CONFIGURATION FOR RIA12 SURGE TEST**

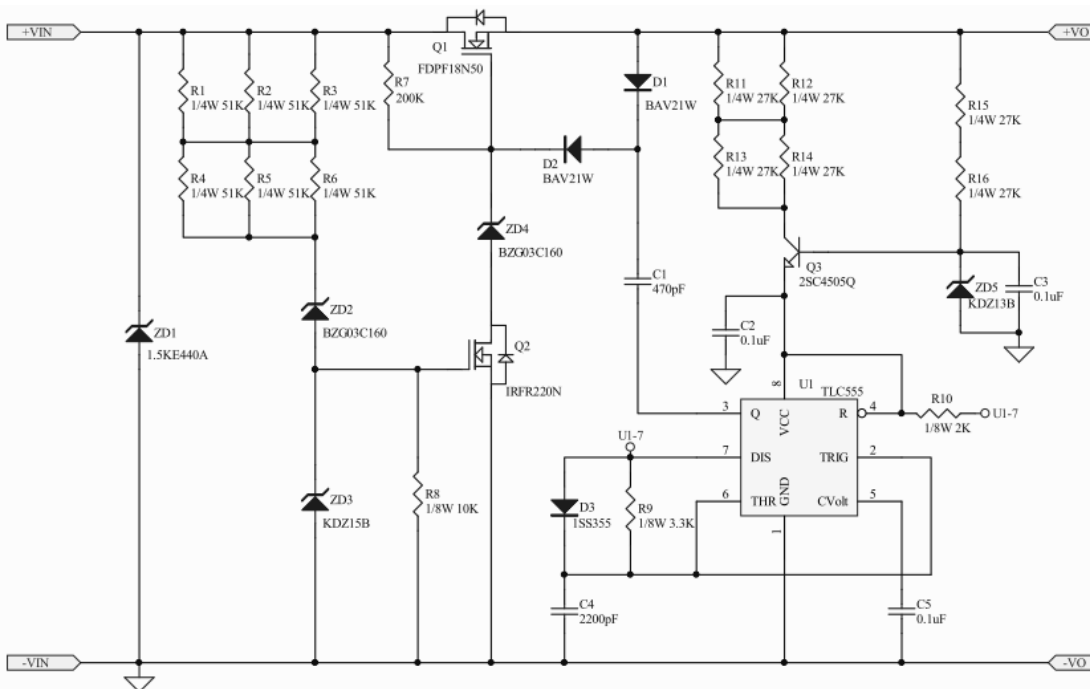

**MECHANICAL SPECIFICATIONS**

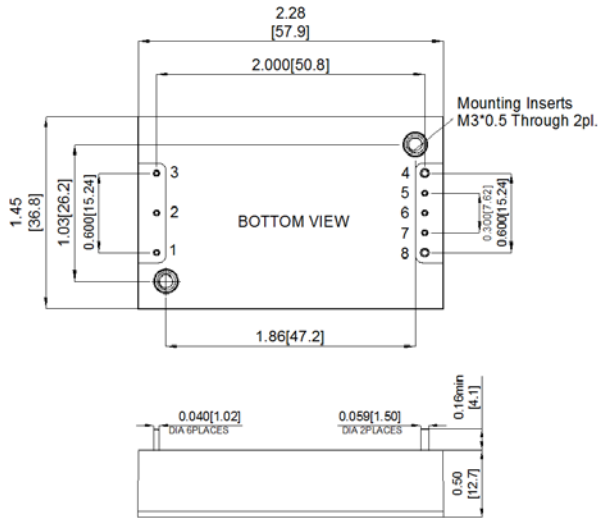

Note: All dimensions are in inches (millimeters). Tolerance: x.xx ±0.02 in. (0.5mm), x.xxx ±0.010 in. (0.25 mm) unless otherwise noted

**PIN CONNECTIONS**

PIN CONNECTIONS	
PIN	SINGLE OUTPUT
1	+ V Input
2	On/Off
3	- V Input
4	-V output
5	-Sense
6	Trim
7	+ Sense
8	+ V Output

**PART NUMBER ORDERING INFORMATION**

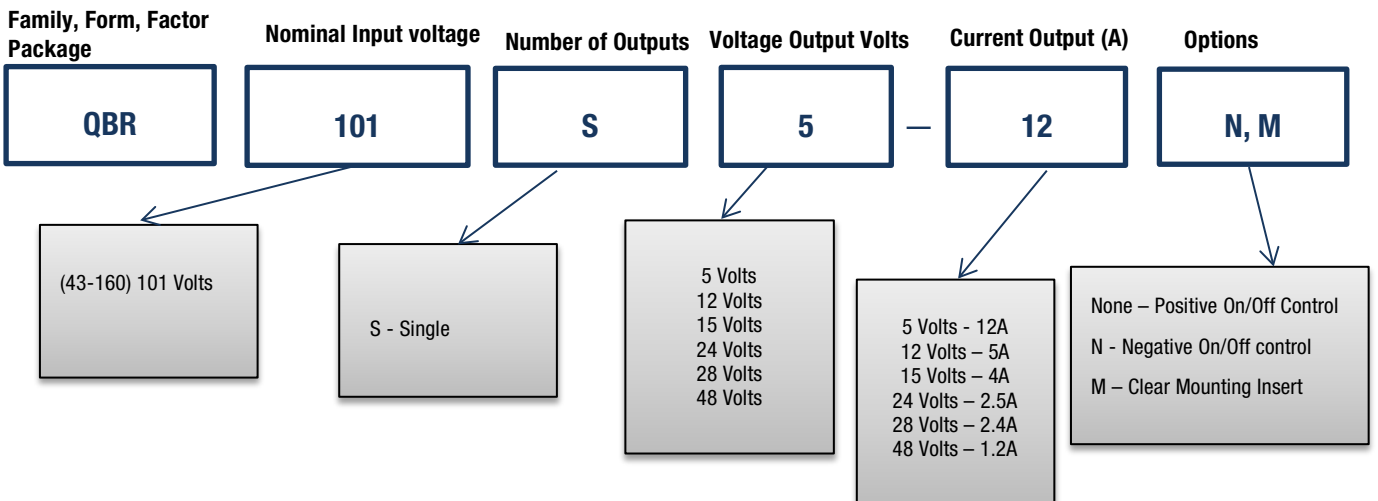

Note: For proper part ordering, enter option suffixes in order listed in table above